



**Pfändler** Beat Headless Bass,  
CH Mitte 1970er-Jahre

DIE ERFINDUNG  
DES  
HEADLESS BASS  
VON  
BEAT PFÄNDLER



**Gibson ES 125, USA 1952**



**Gibson Les Paul Gold Top, USA 1952**



**Gibson Super 400 CES, USA 1955**



**Gibson Les Paul Junior, USA 1957**



**Gibson Les Paul Custom, USA 1958**



**Gibson SG, USA 1962**



**Gibson Firebird I, USA ab 1963**



**Gibson ES 335, USA 1967**



**Gibson Flying V, USA 1971**



**Gibson Les Paul Recording, USA 1972**



**Gibson Thunderbird 76, USA 1976**



**Gibson Flying V2 «Boomerang», USA 1979/81**



**Gibson Explorer 76, USA 1991**



**Gibson Les Paul Standard, USA 1993**



**Gibson Explorer Centennial, USA 1994**



**Gibson Flying V Centennial, USA 1994**



**Gretsch Country Gentleman, Mitte 1960er-Jahre**



**Hagström Kent, Schweden 1966/67**



**Höfner Golden, D um 1960**



**Höfner «Beatle Bass» Modell 500/1, D 1962**



**Höfner Shorty, D 1975-1980**



**Jackson Black Special Power Force, USA**



**National Resonator Tricone (Tri-Plate), USA 1929**



**National New Yorker, USA 1956**

# Stromgitarren

(Legende)



**Acid Rock**



**Bigsby Solidbody Reissue,**  
USA ca. 1995



**Blade RH-4 Classic,** CH  
2005



**Bond Electraglide,** GB 1986



**Casio DG 20 Digital Guitar,**  
Japan 1987



**Clearsound «Strat»,** Japan  
1978



**Crucianelli Elite 30-V,** Italien  
1962



**Eigenbau Bass Fretless**  
Lefthand, CH 1977



**Eigenbau Roger Vogel,** CH  
1965



**Eko Flying**



**Epiphone Broadway,** USA  
1931



**Epiphone SG Special**



**Fender Broadcaster,** USA  
1950



**Fender Telecaster,** USA 1959



**Fender Precision Bass,** USA  
1965



**Fender Jaguar,** USA 1966



**Fender Electric 12,** USA  
1966



**Fender Mustang,** USA 1966



**Fender Jazzmaster,** USA  
1966



**Fender Jazz Bass,** USA 1977



**Fender Stratocaster,** USA  
1978



**Fender Stratocaster Buddy**  
Guy Signature, USA 2000



**Fernandes,** Japan 1980er-  
Jahre



**Formanta 1970 Collection,**  
UdSSR ca. 1980



**Pfändler** Beat Headless Bass,  
CH Mitte 1970er-Jahre



**Resident Evil**, USA



**Rickenbacker** A-22 «Frying  
Pan», USA 1934



**Rickenbacker** 450, USA um  
1960



**Rickenbacker** Bass 4001,  
USA 1974



**Silvertone** (Teisco) Amp-  
on-Board, USA/Japan Mitte  
1960er-Jahre



**Soultool** Gemini Blue  
Translucent, CH 2004



**Terminator**, USA um 2000



**Terminator** Power Force



**VOX** Bass, GB 1960er-Jahre



**VOX** Spitfire, GB 1965



**Washburn** Bantam, USA  
1980er-Jahre



# Kinderzeichnung mit 10 Jahren: Laufrad Konstruktion

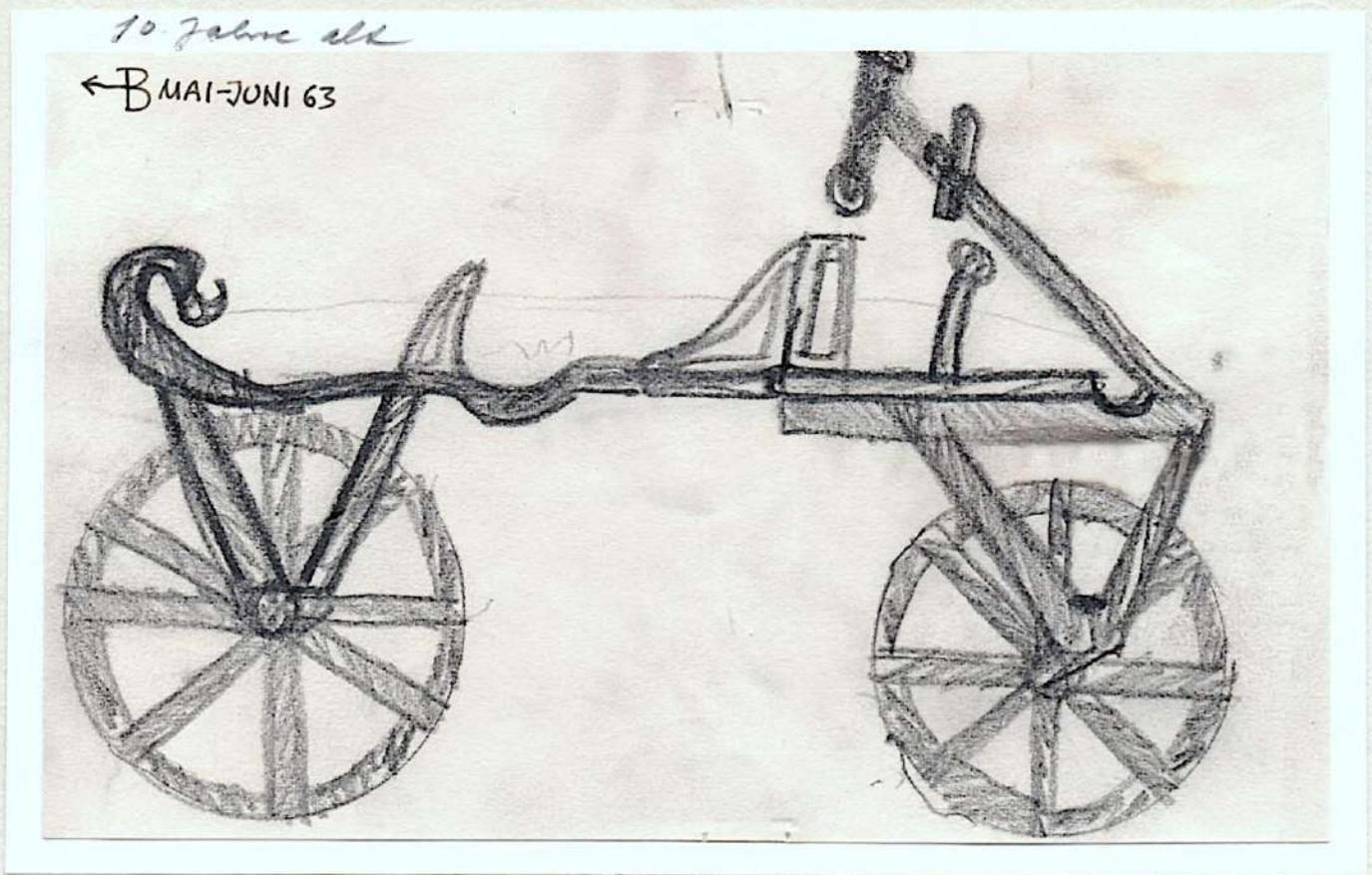



Bassist in Jazz-Rock Band mit 20 Jahren



297. 55. 98  
Maharishim

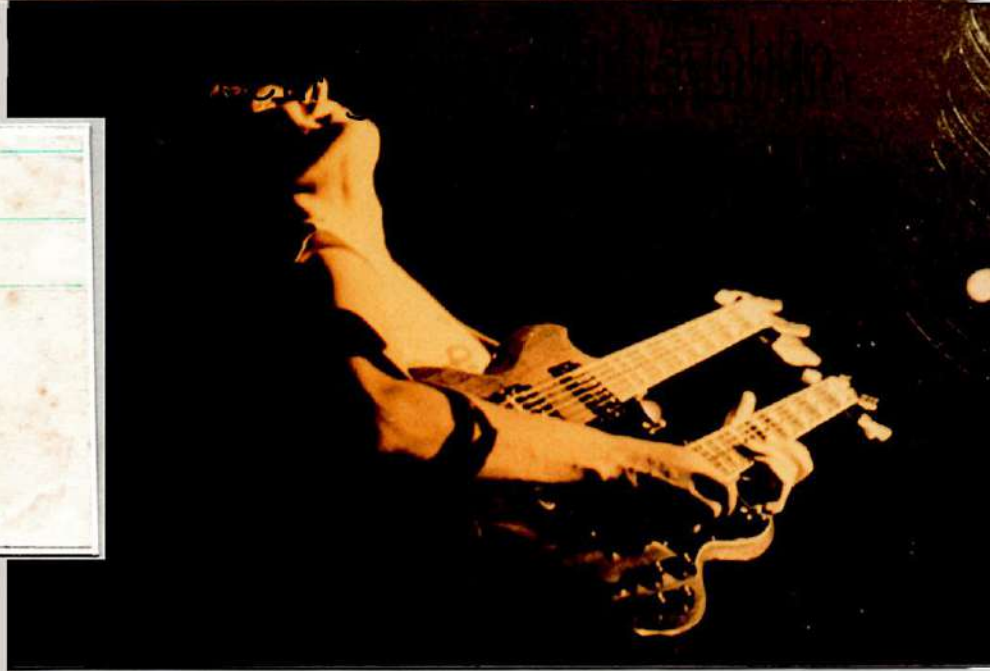

Meeting John McLaughlin in New York



Erster Doppelhals Bass



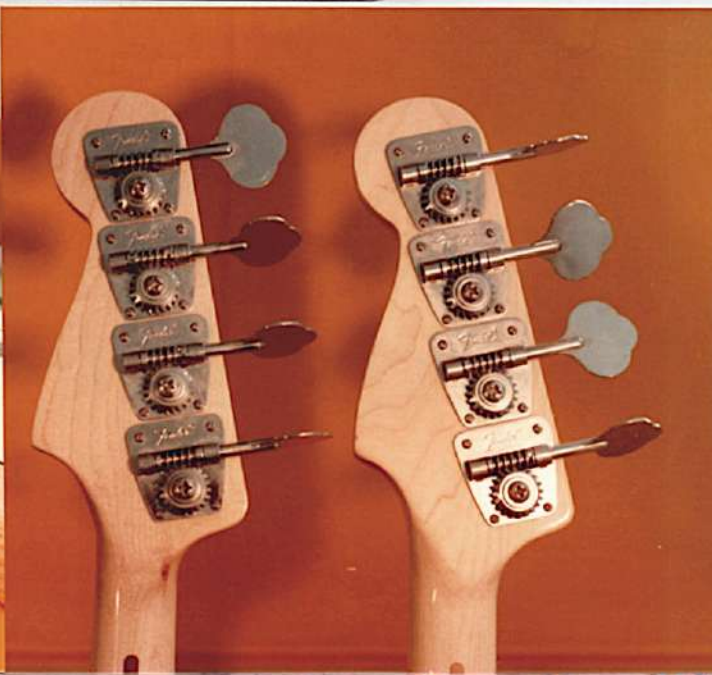

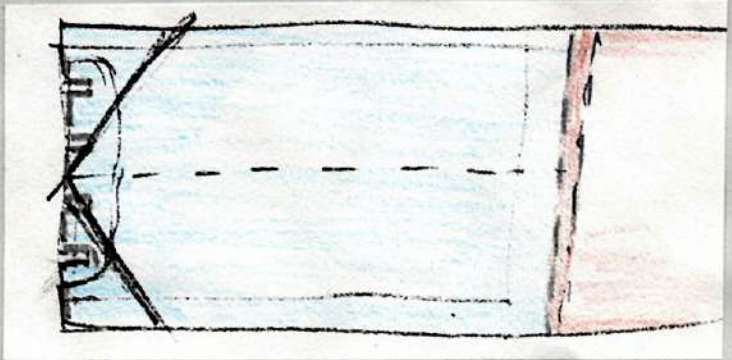
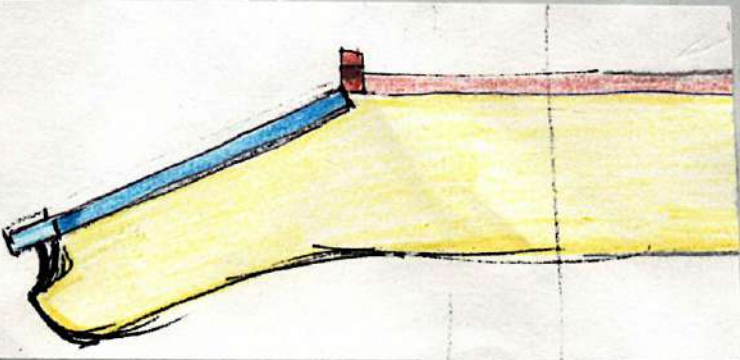
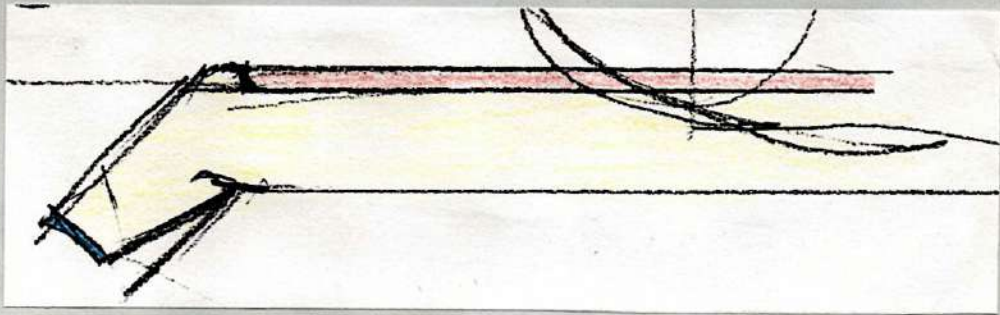
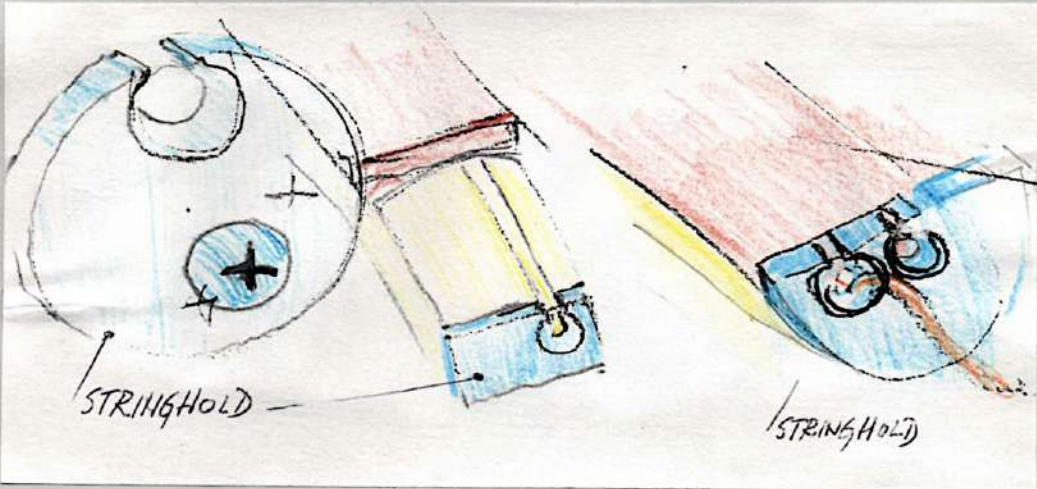
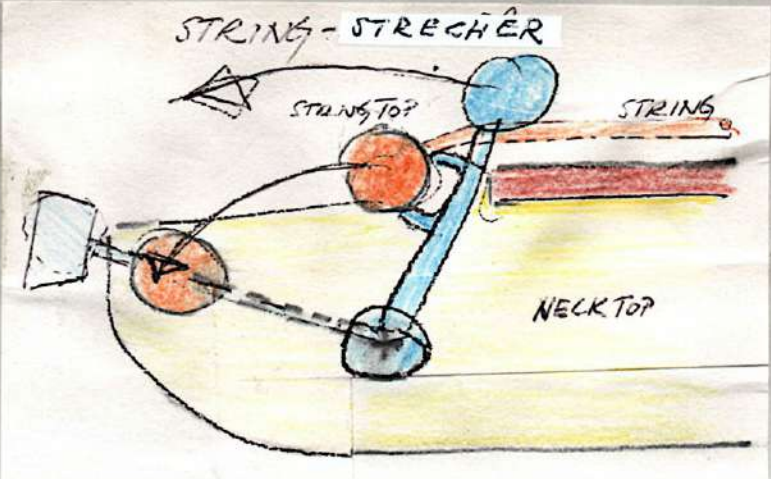
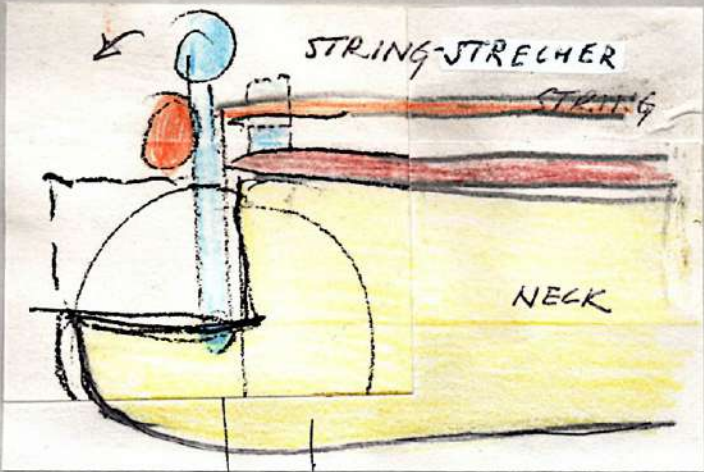

Ideen für einen Reise-Bass

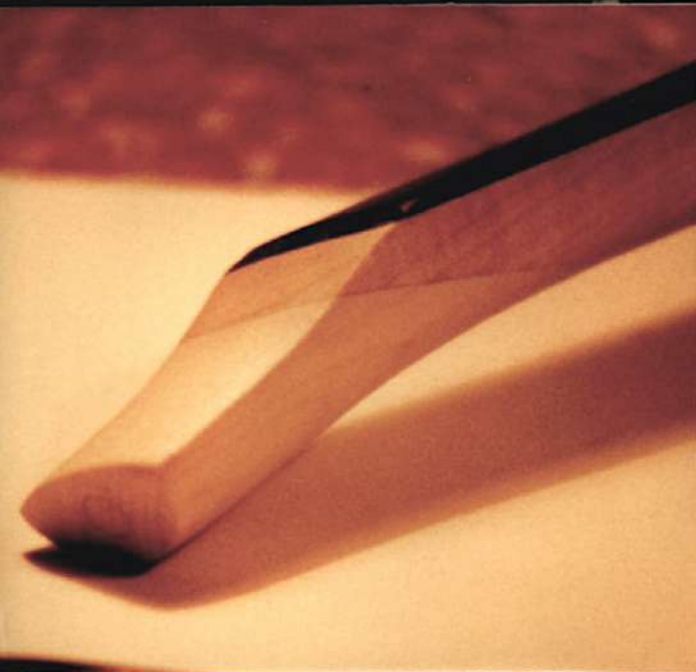
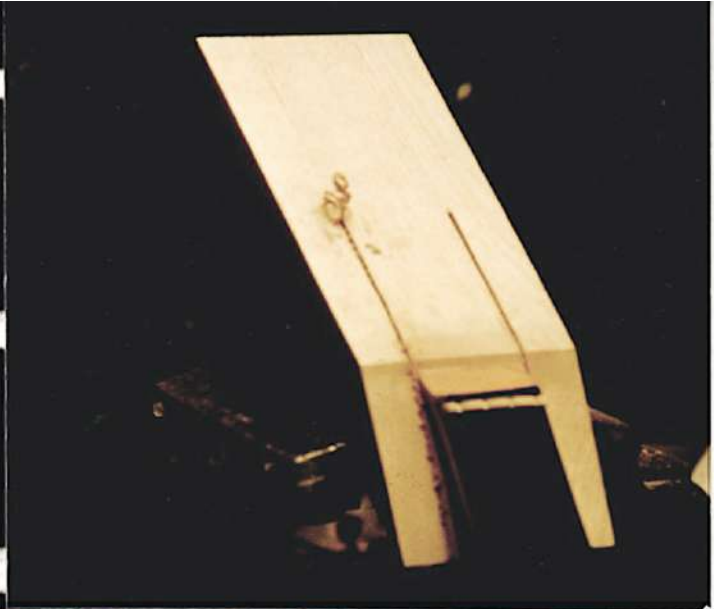

MINI-TRAVEL-BASS BEAT PFANDLER 22.2.76  
 MASSTAB 1:1 MASSE IN mm

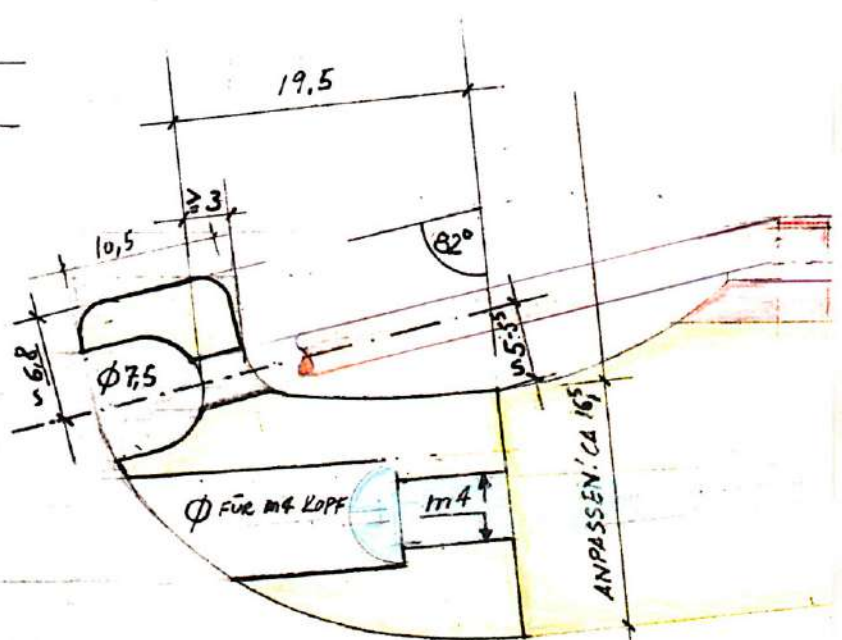
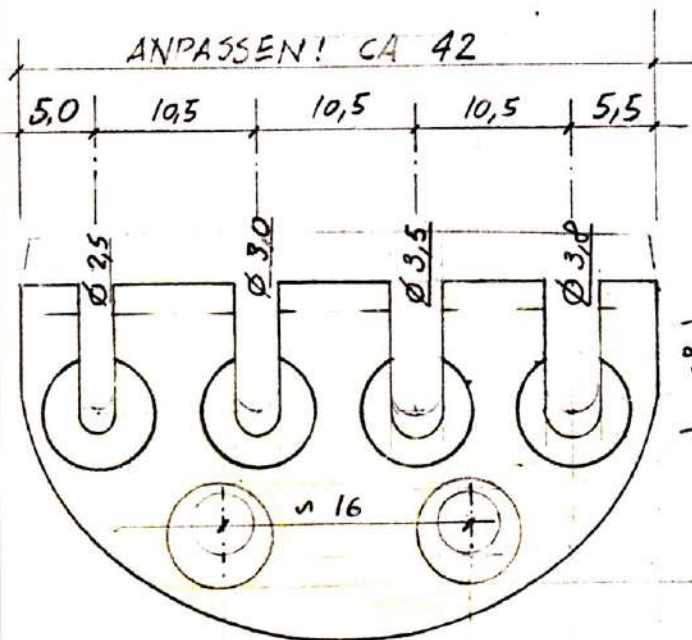

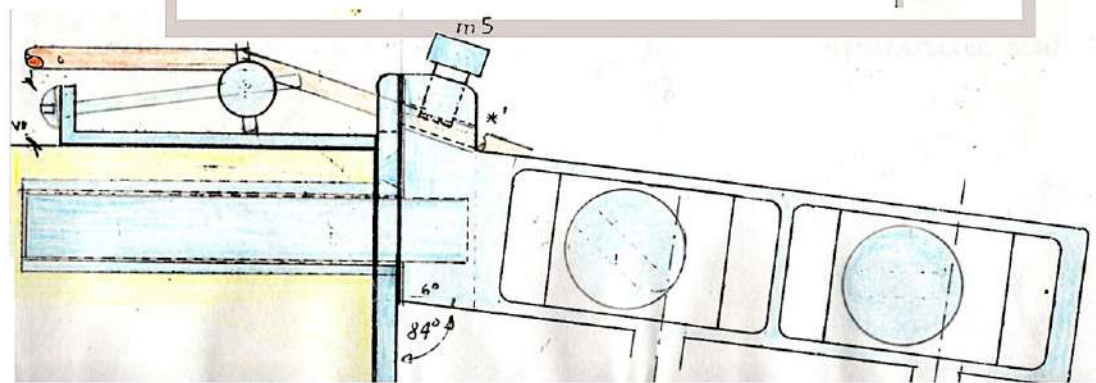
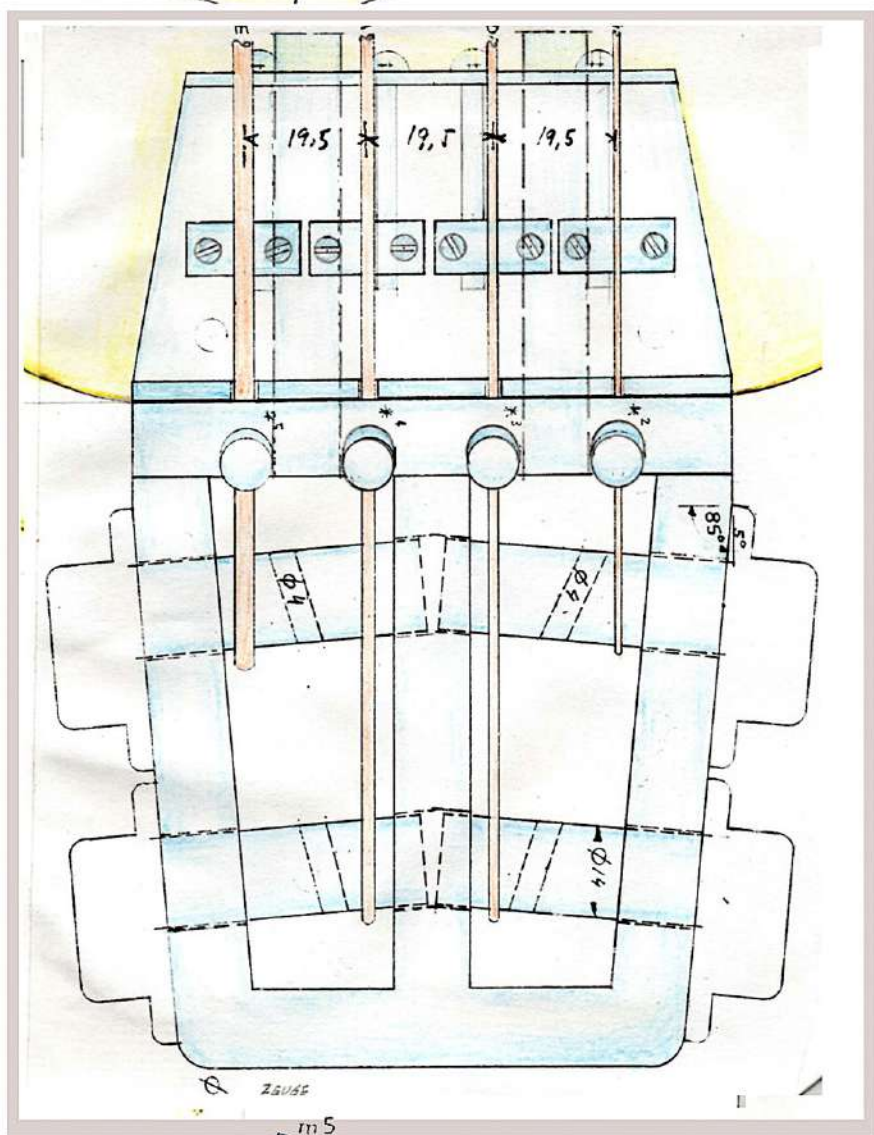
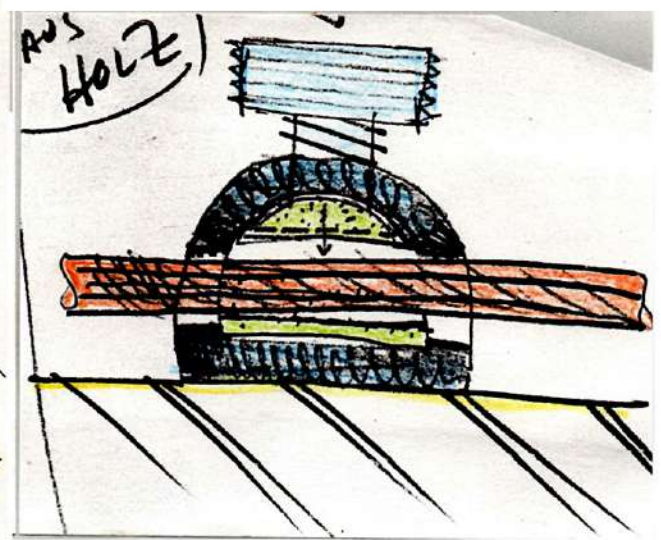
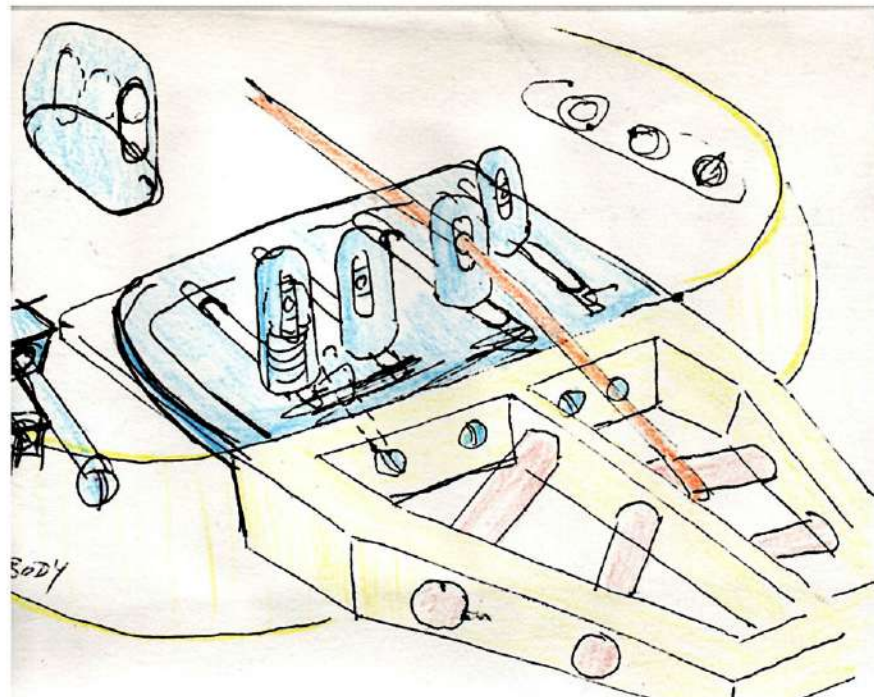

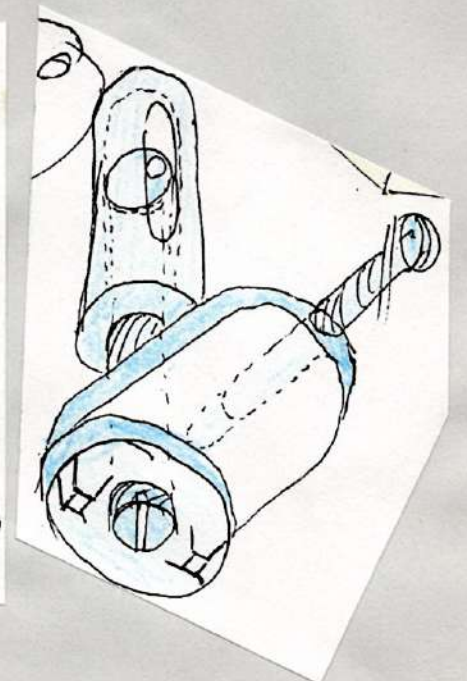
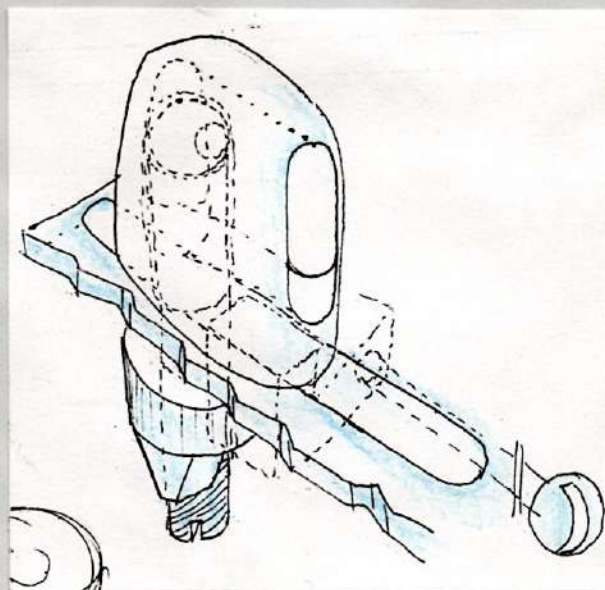
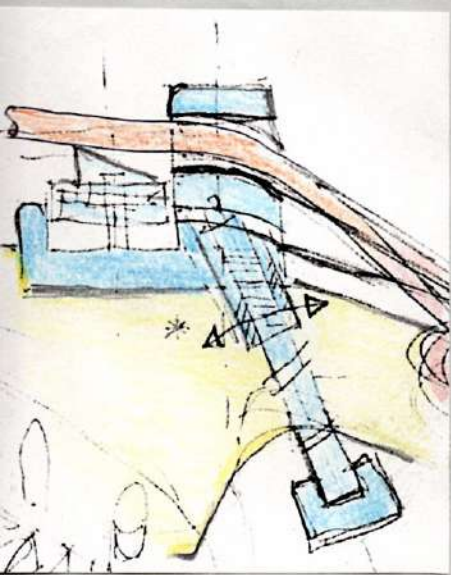
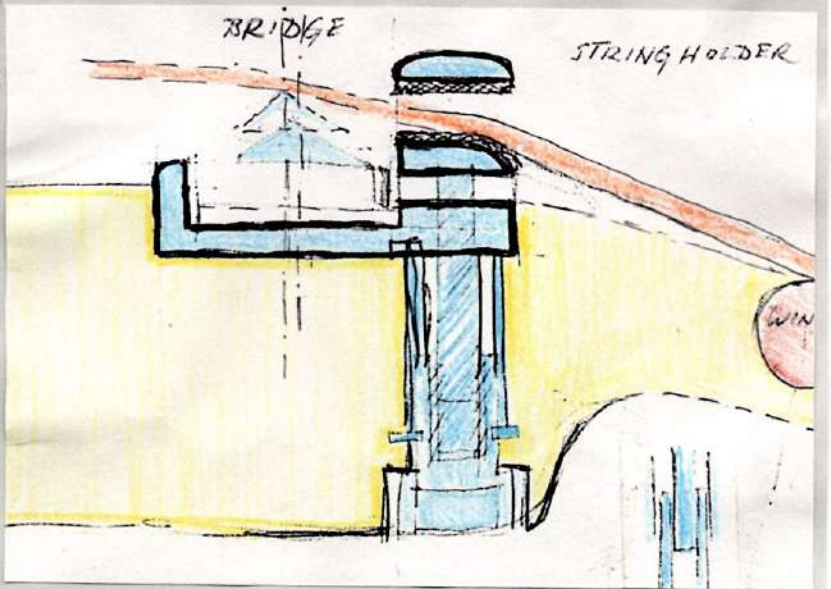
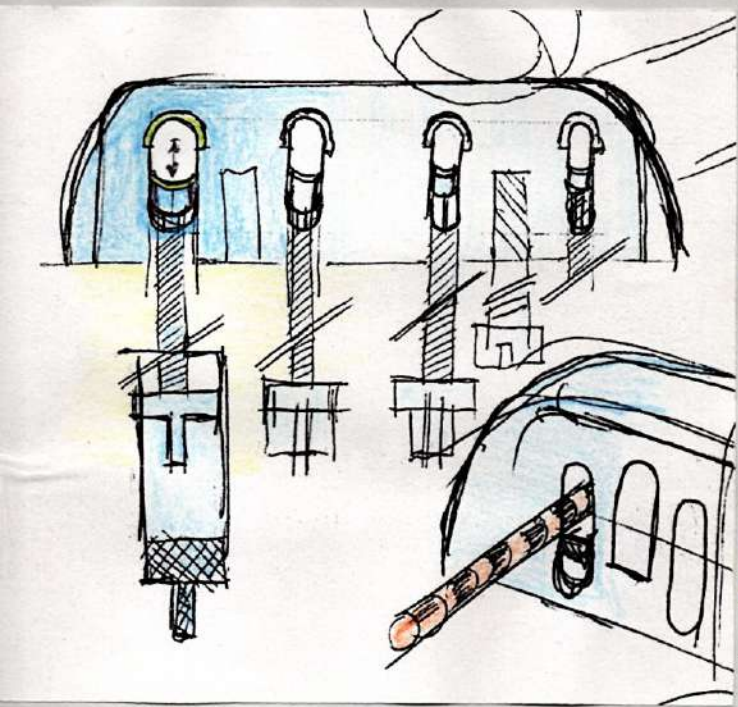
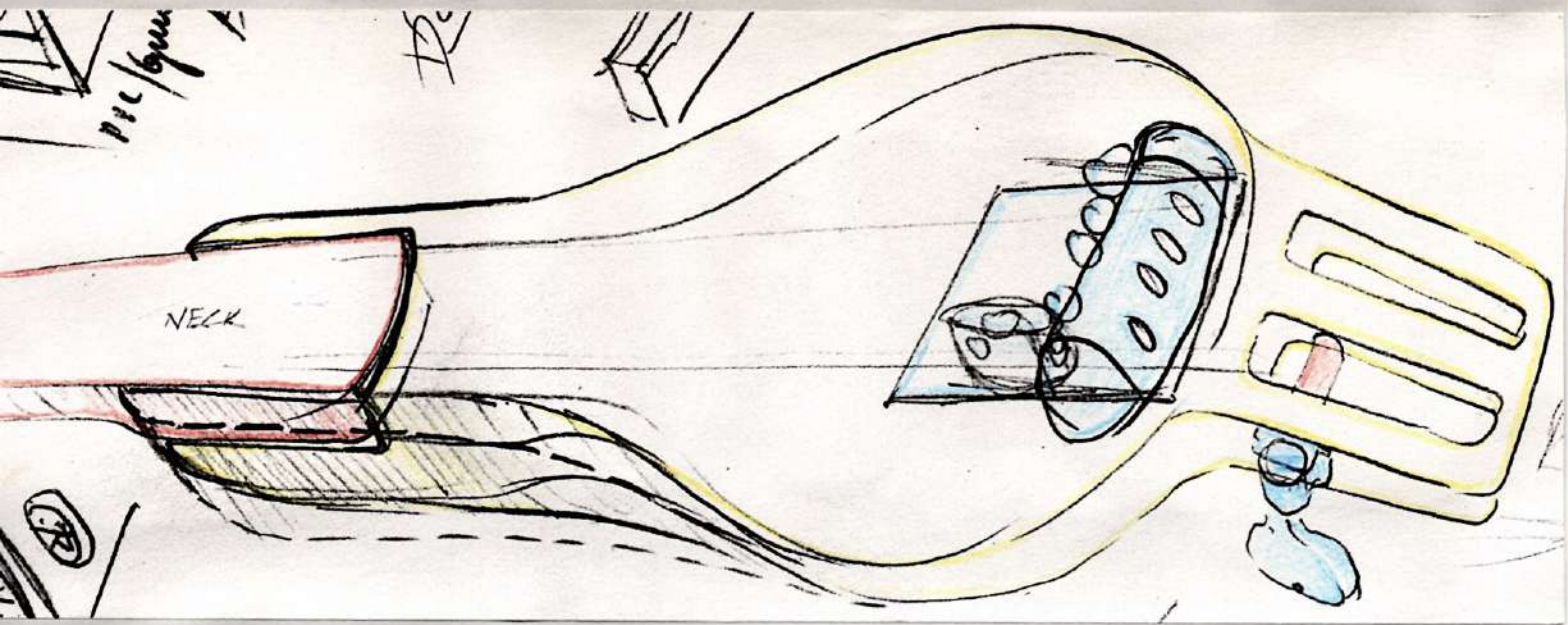

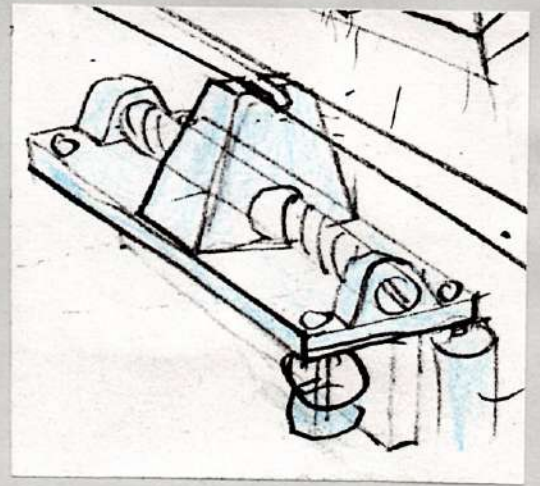
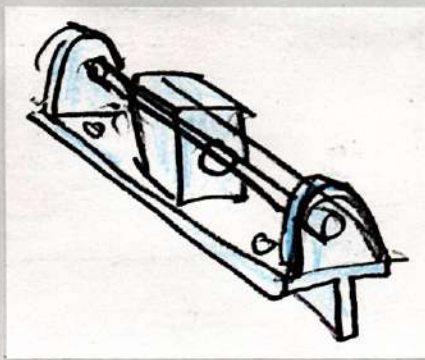
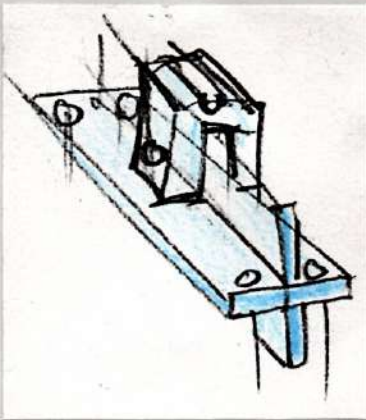
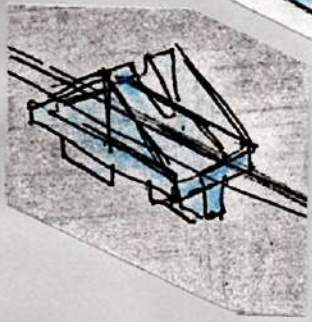
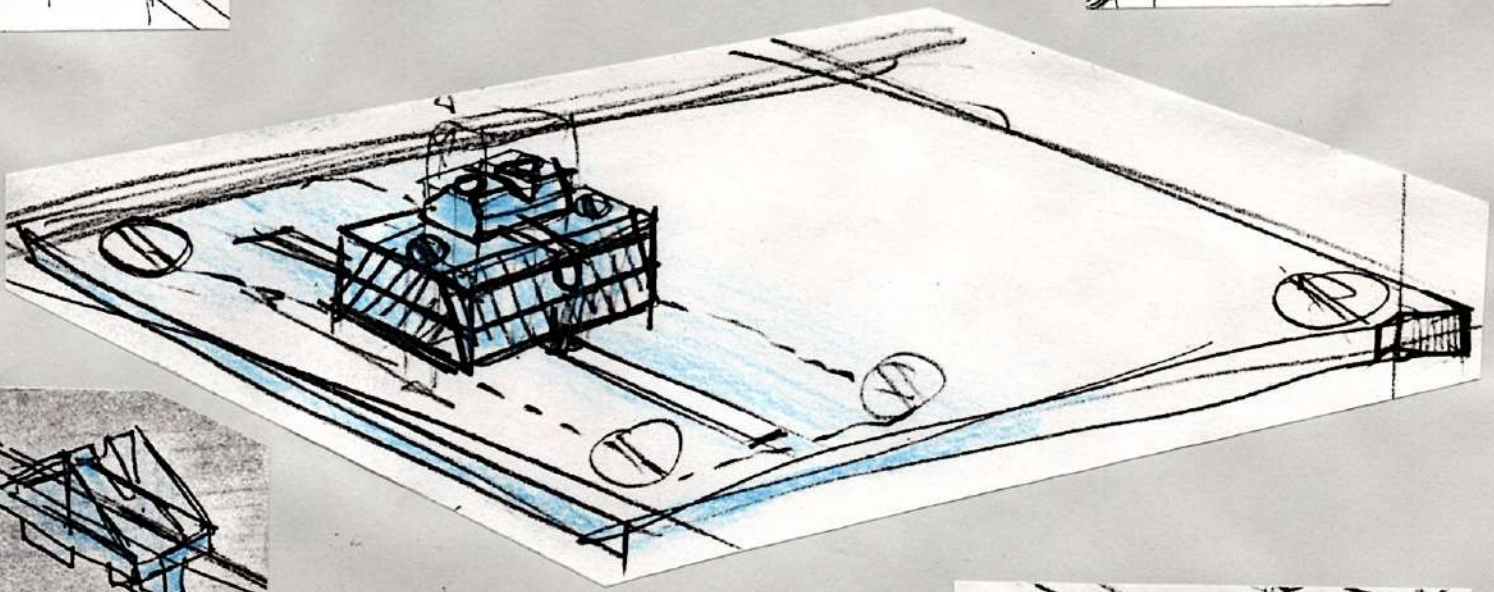
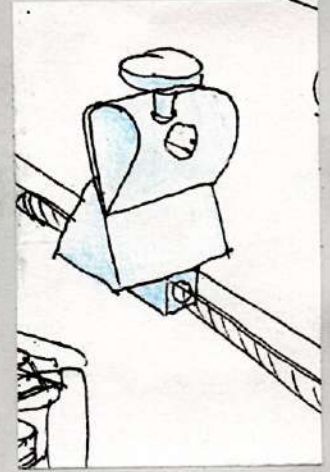
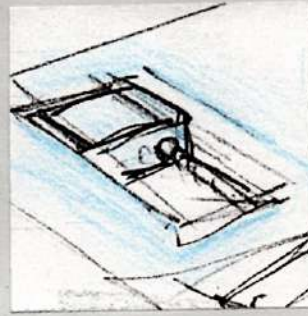
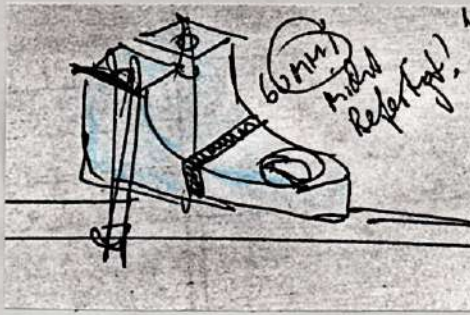
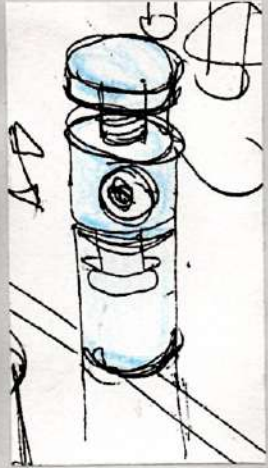
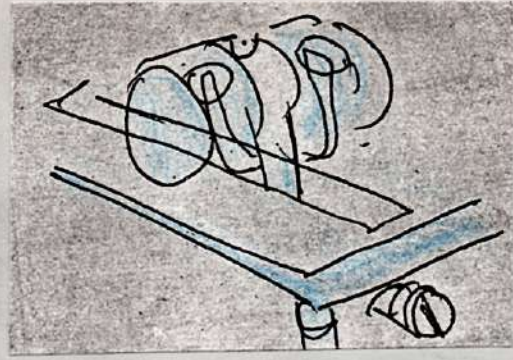
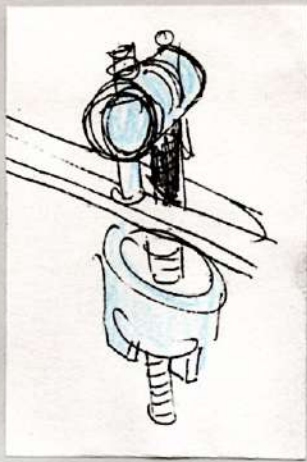
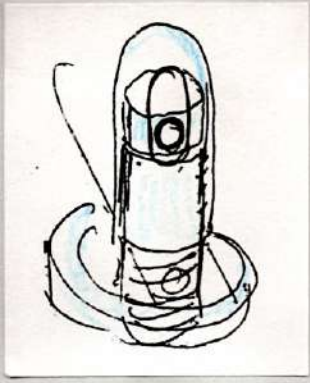

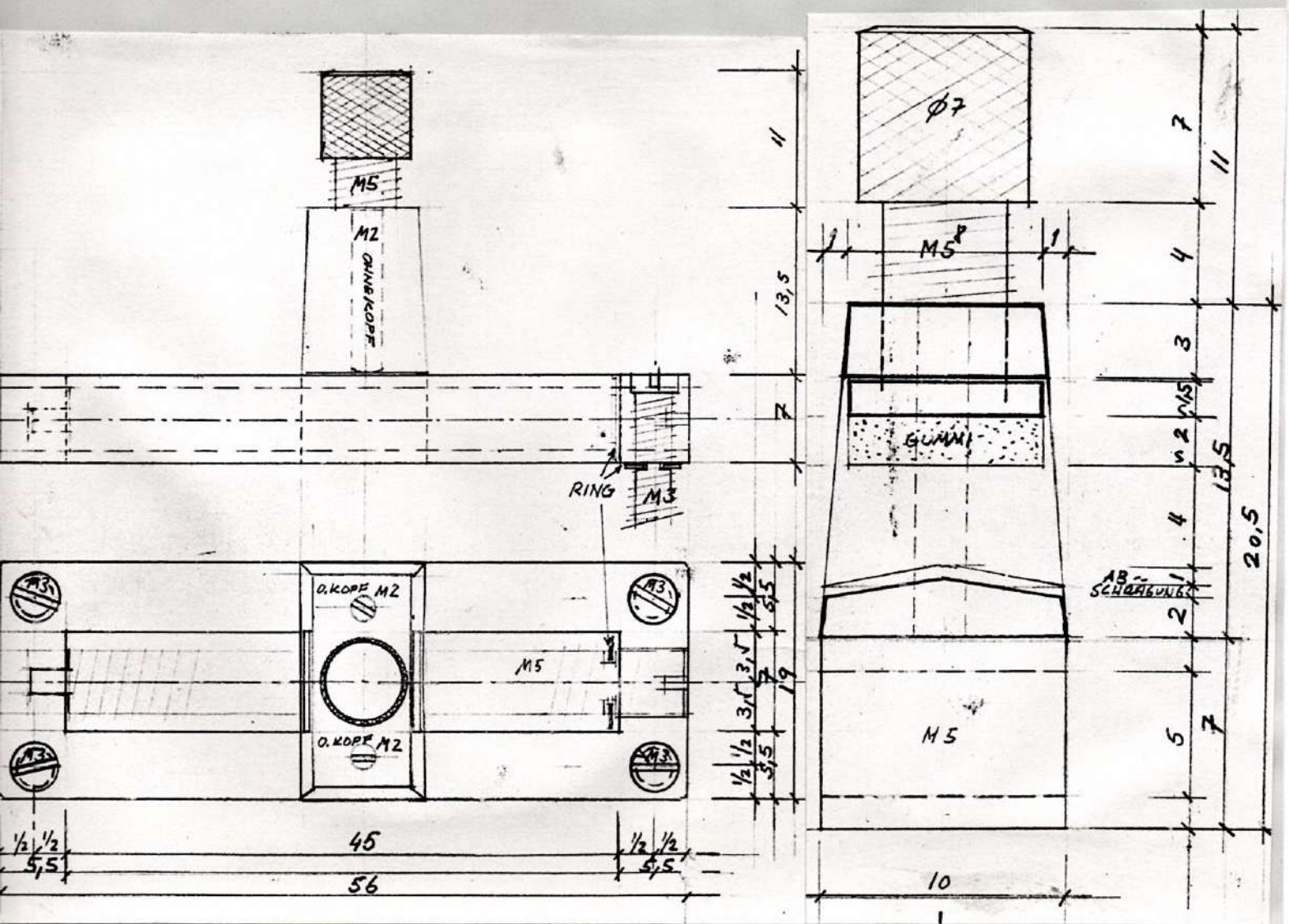
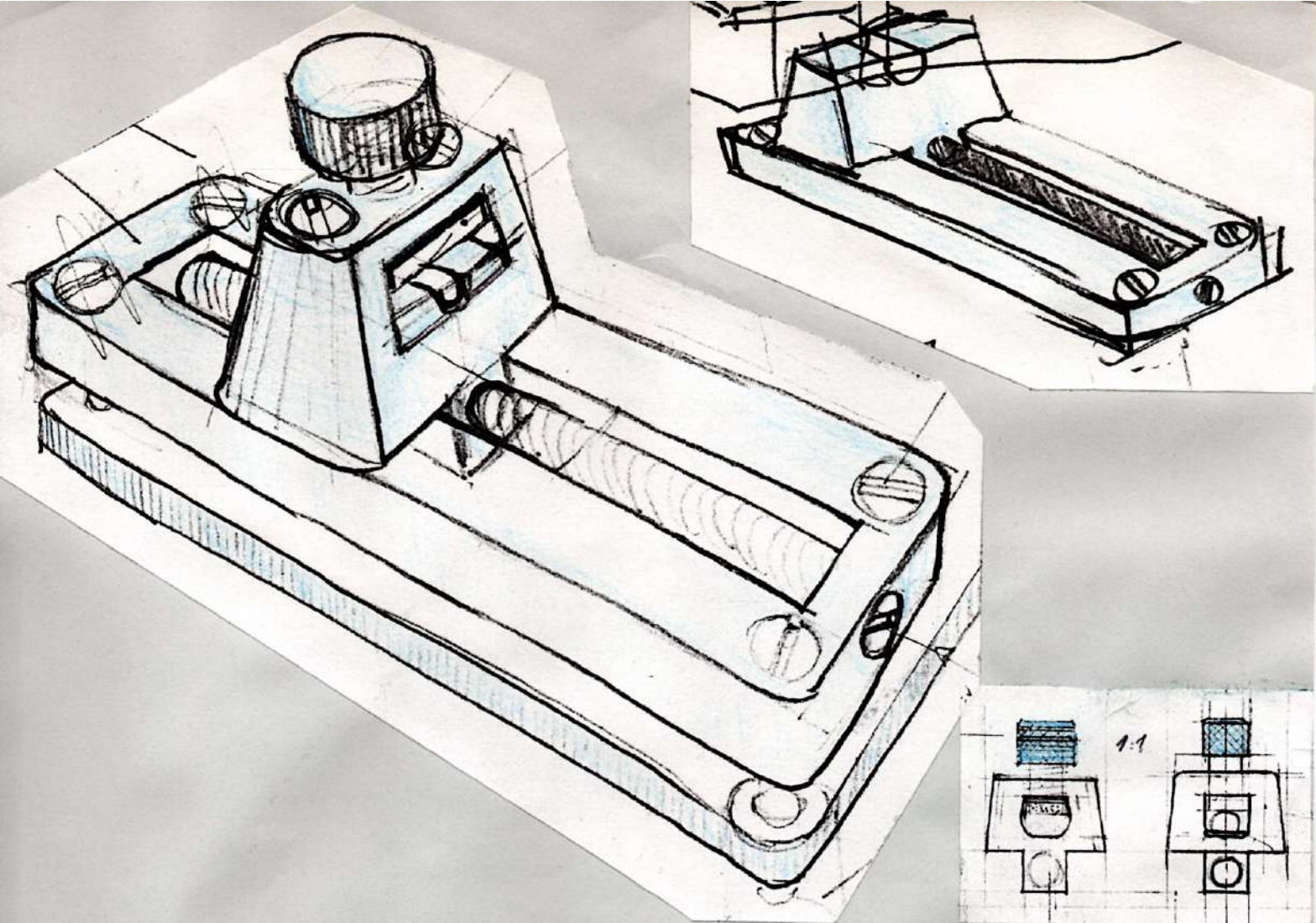

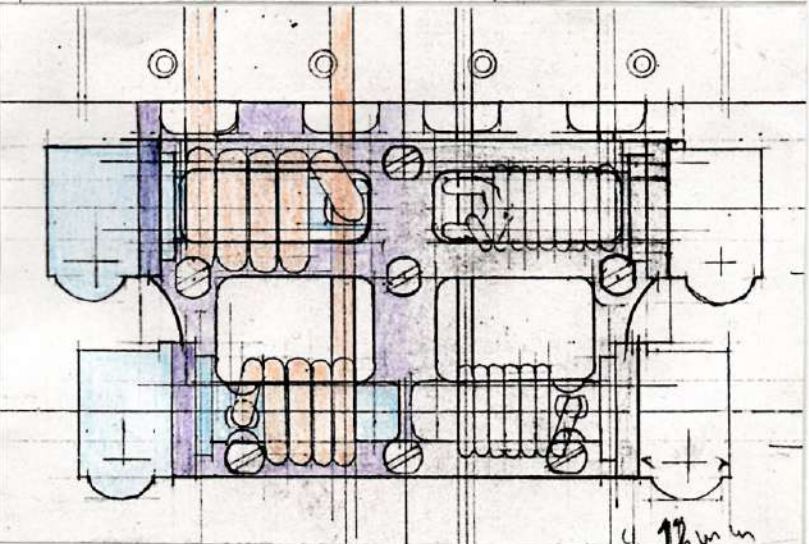
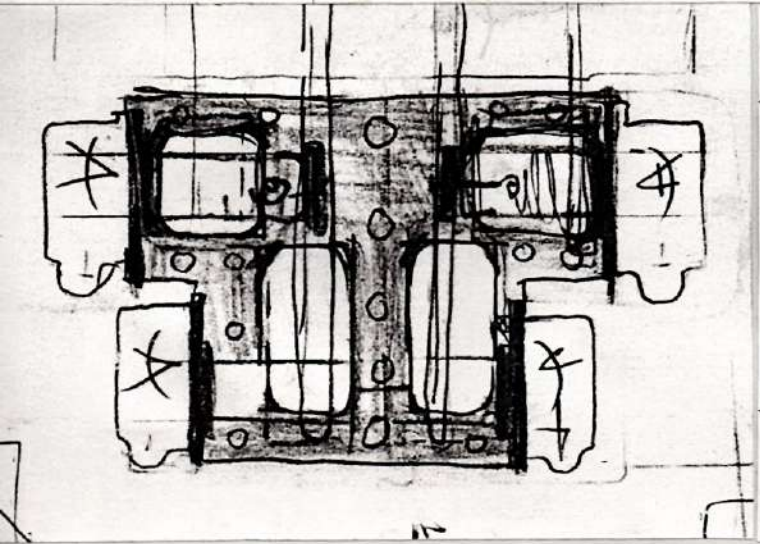
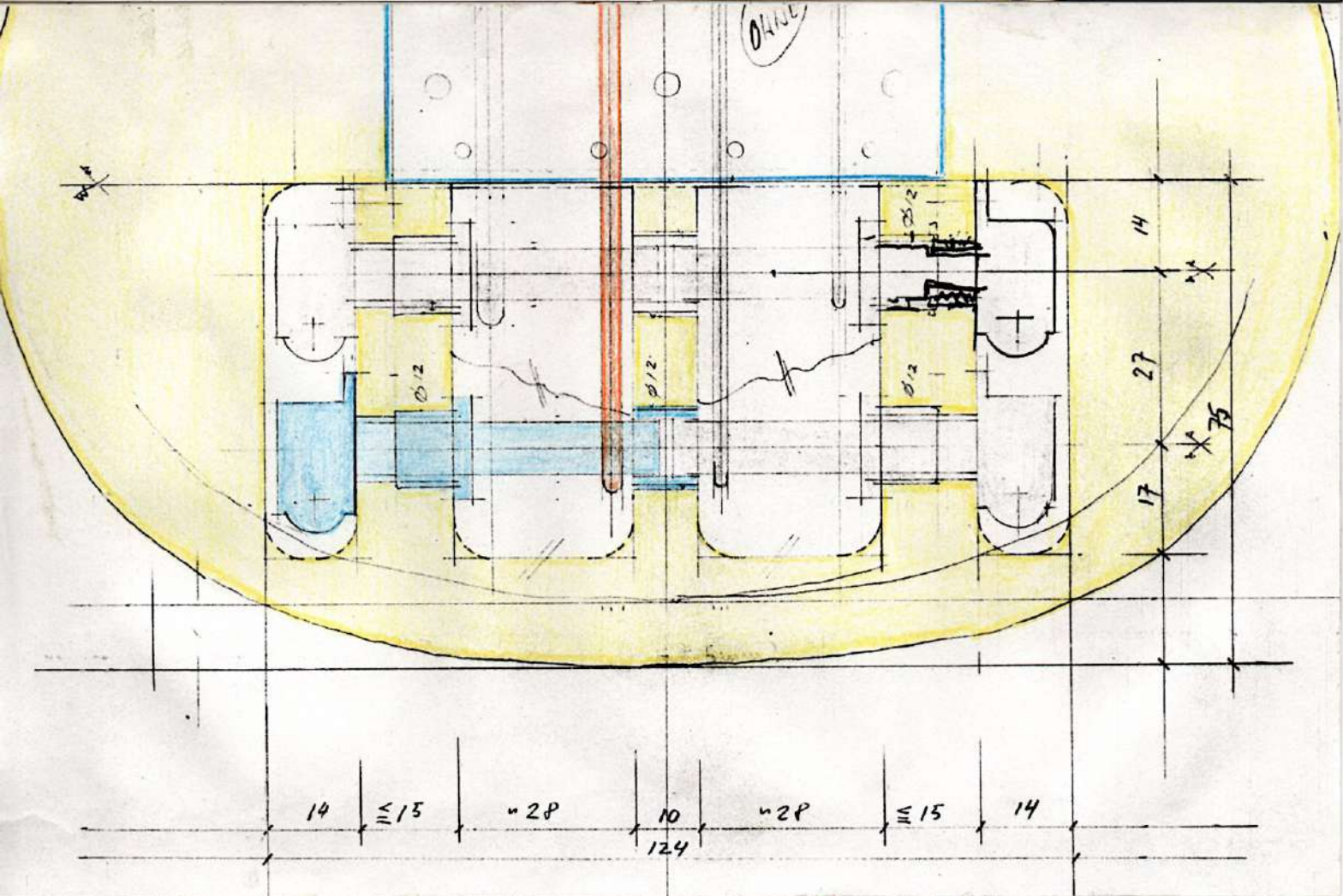
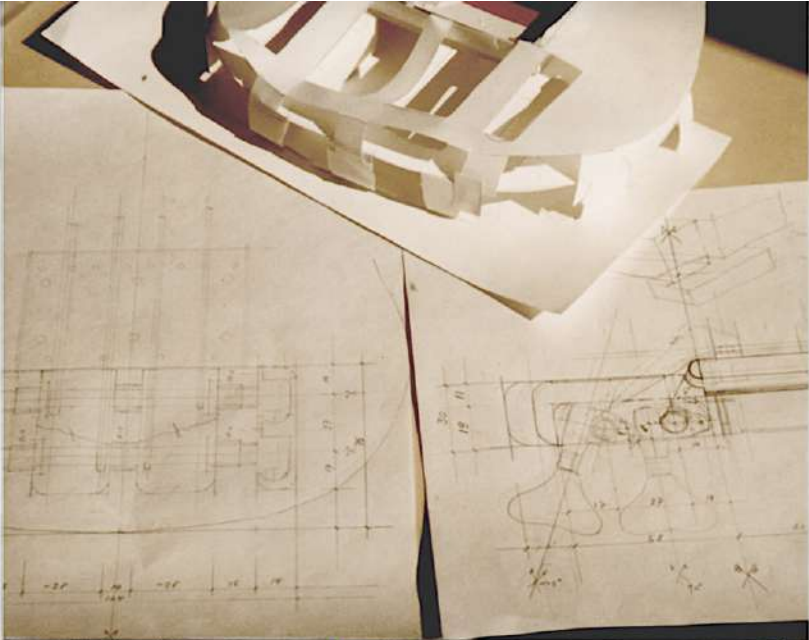





to  Boten  Abgeholt von

|                                     |      |  |       |
|-------------------------------------|------|--|-------|
| Latt Vogelaugeahorn                 |      |  |       |
| $2.35 \cdot 32 = 0.752 \text{ m}^2$ |      |  |       |
| -p. m <sup>2</sup>                  | 15,- |  | 11.30 |
|                                     | 3%   |  | 10.95 |
| Wust                                | 5.6% |  | 11.55 |





**Eidgenössisches Amt für geistiges Eigentum**  
**Bureau fédéral de la propriété intellectuelle**  
**Ufficio federale della proprietà intellettuale**

3003 BERN

Postscheck Chèques post. 30-4000

☎ (031) 61 41 11

Telex 33130 AGE CH

**Anmeldung eines Erfindungspatentes**  
**Dépôt d'une demande de brevet d'invention**  
**Deposito di una domanda di brevetto**



**Bundesamt für geistiges Eigentum**  
**Office fédéral de la propriété intellectuelle**  
**Ufficio federale della proprietà intellettuale**

3003 BERN

Postscheck Chèques post. 30-4000

☎ (031) 61 41 11

Telex 33130 AGE CH

26.3.1975

Mit diesem Schreiben erheben wir die Gebühren für die Anmeldung eines Erfindungspatentes. Die Gebühren sind in den Merkblättern mit Hinweisen auf die geltenden Bestimmungen angegeben. Falls Sie ohne Hilfe eines Patentanwalts oder eines anderen Sachverständigen im Gebiet des Patentwesens die Anmeldung durchführen, empfehlen wir Ihnen, sich an einen Patentanwalt zu wenden.

**Pauschalfrankiert**  
**Affranchi à forfait**



**Eidgenössisches Amt für geistiges Eigentum**  
**Bureau fédéral de la propriété intellectuelle**  
**Ufficio federale della proprietà intellettuale**

3003 BERN

Instrumentenbau  
 Beat Pfändler  
 Olgastr. 10  
 8001 Zürich

STUDIO - TRAVEL - BASS  
SCHNITT & GRUNDRISSE  
MUSIKSTUDIO PFÄNDLER  
PATENT PENDING

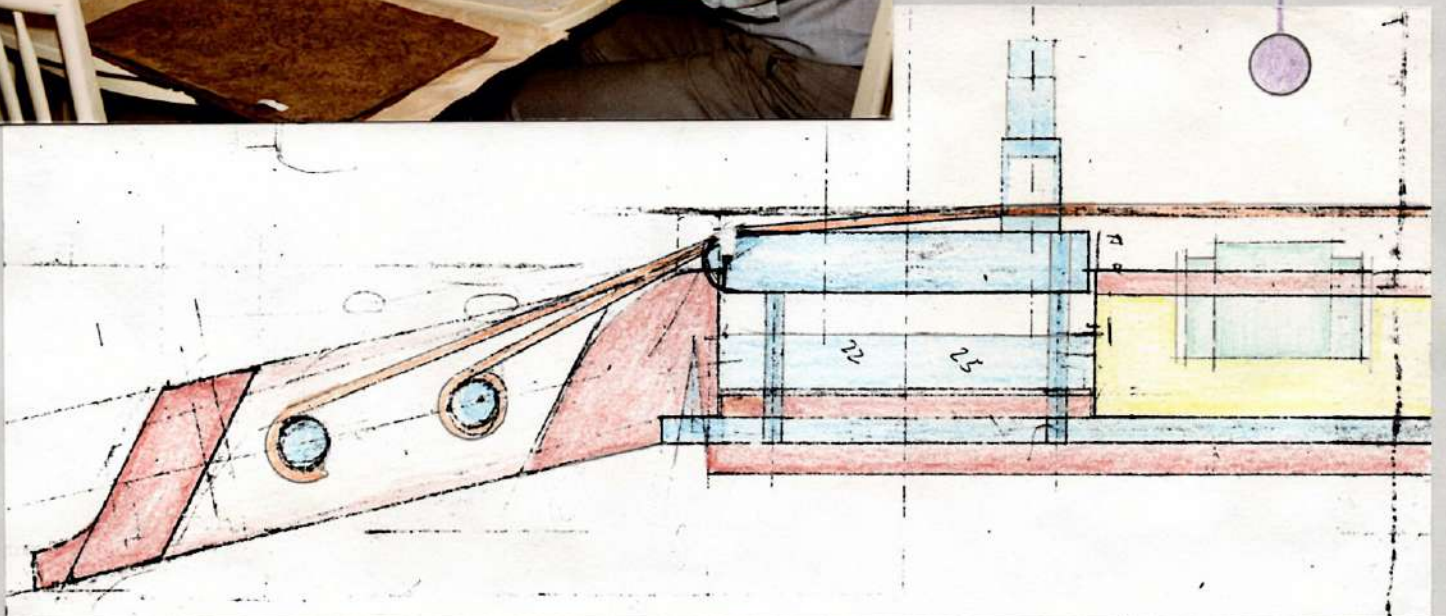
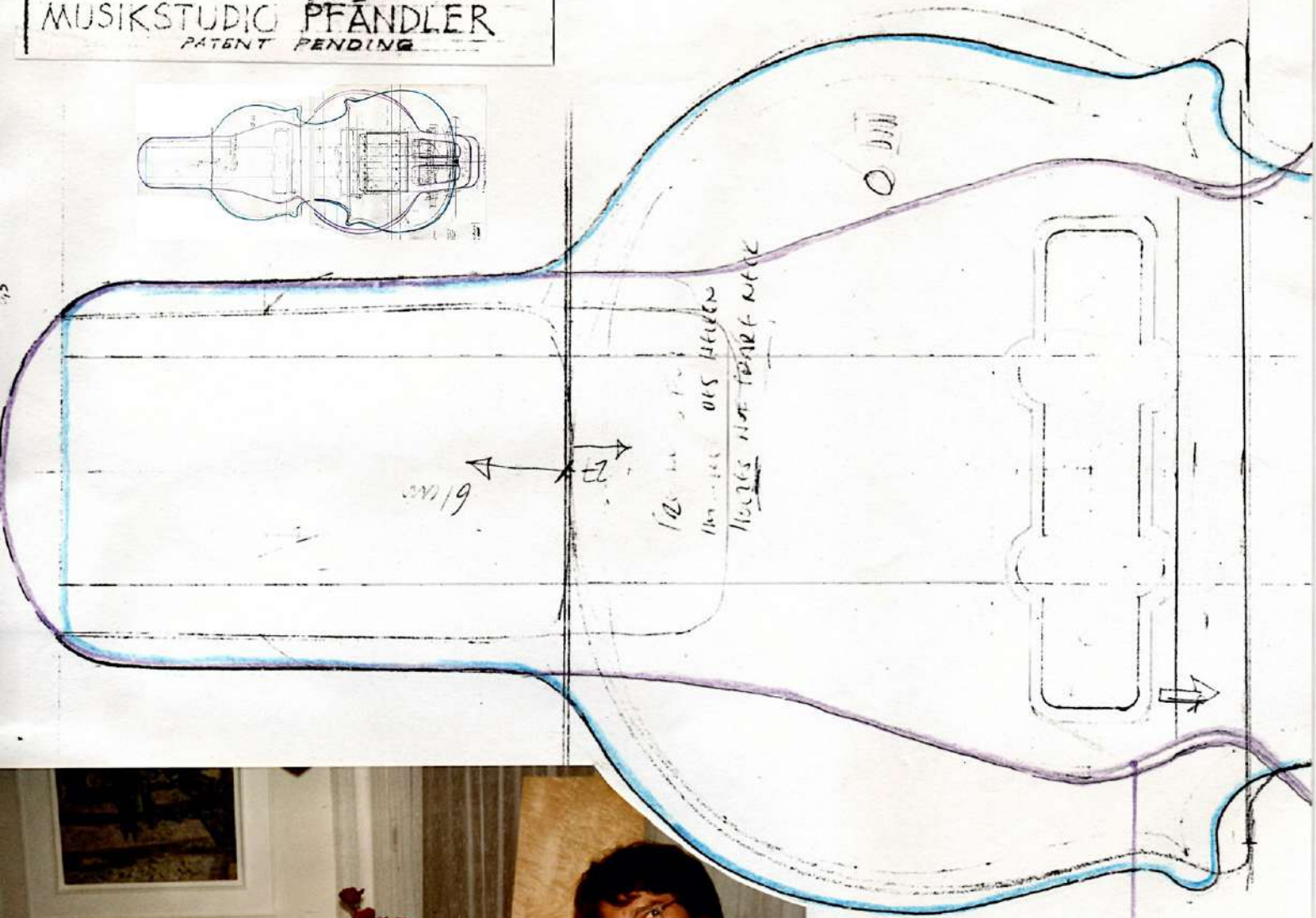
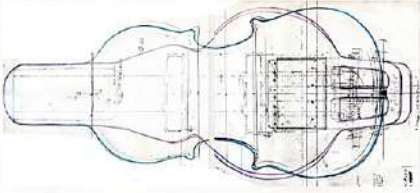

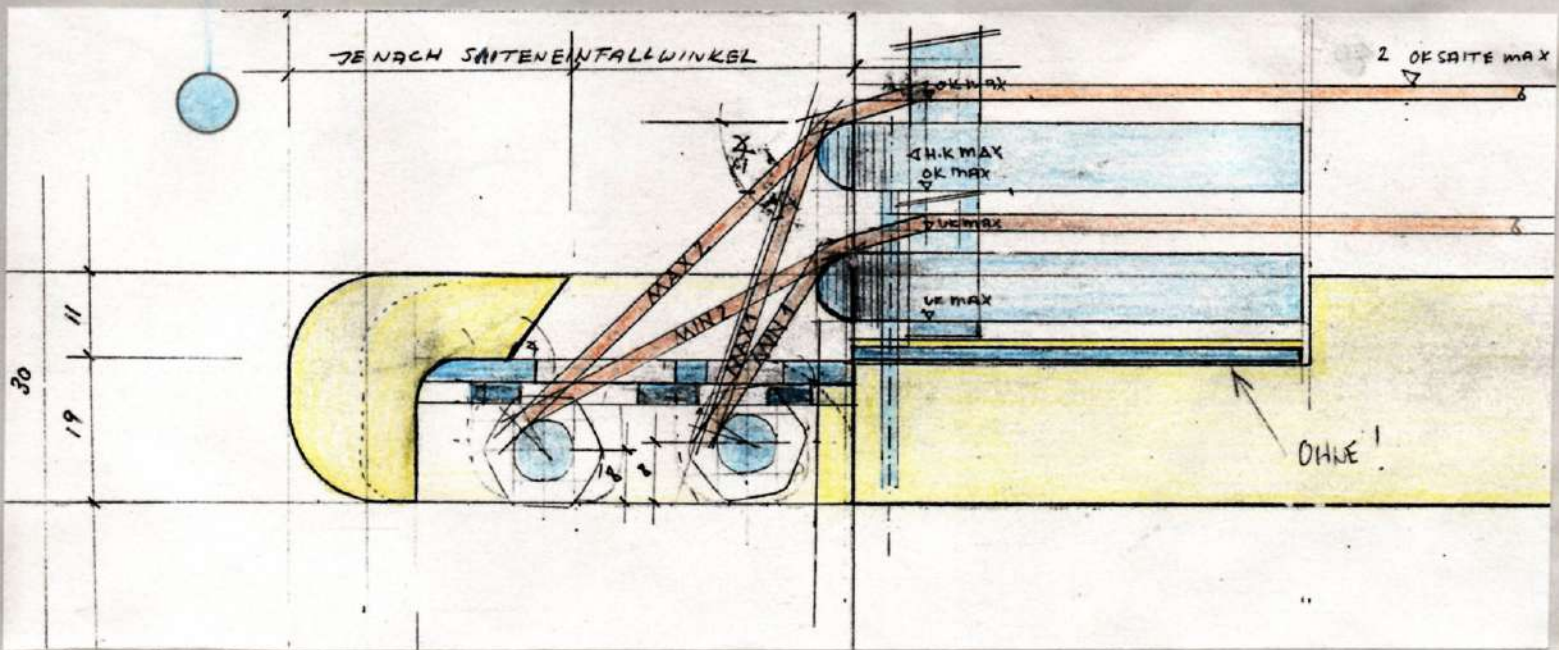
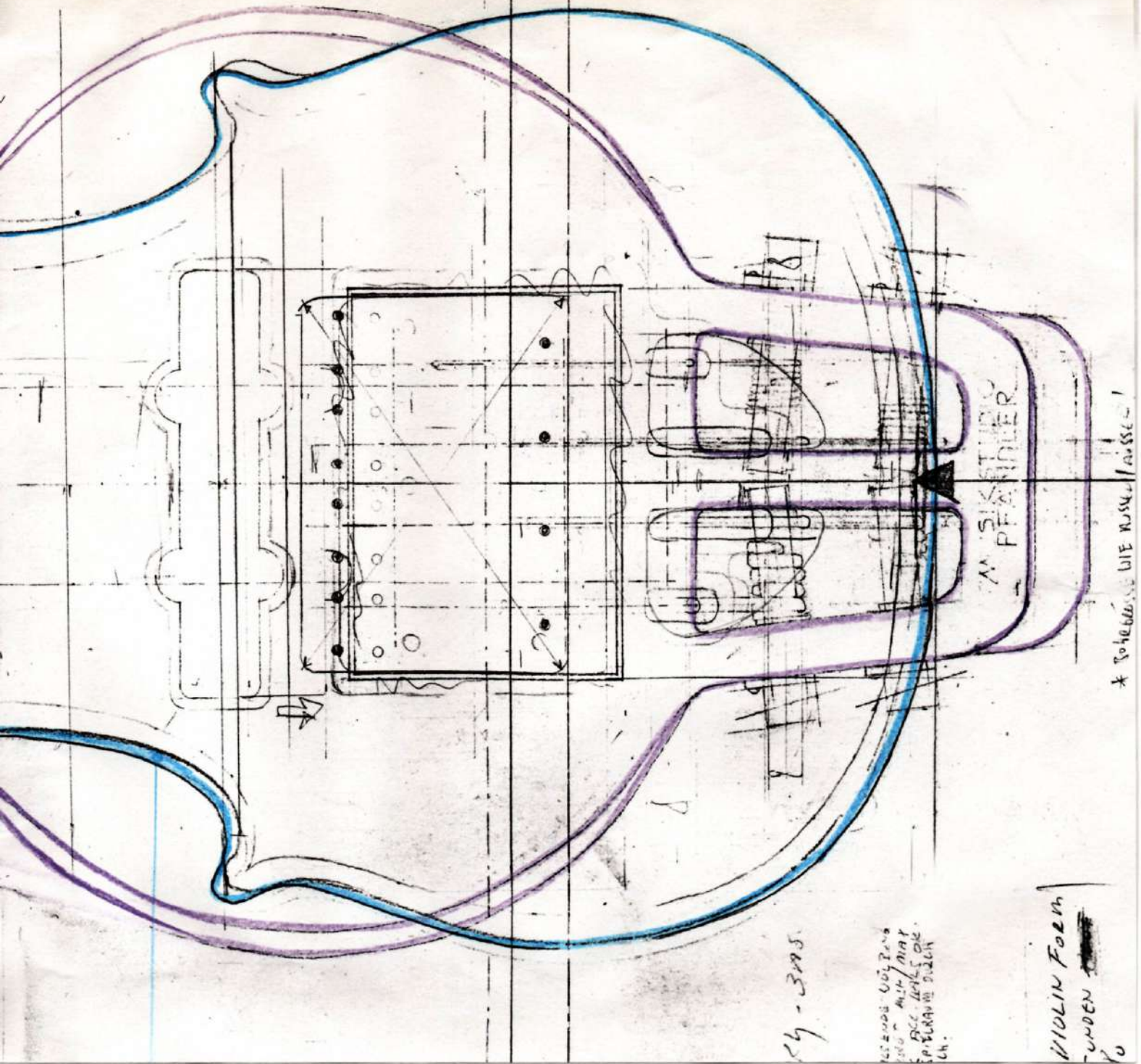

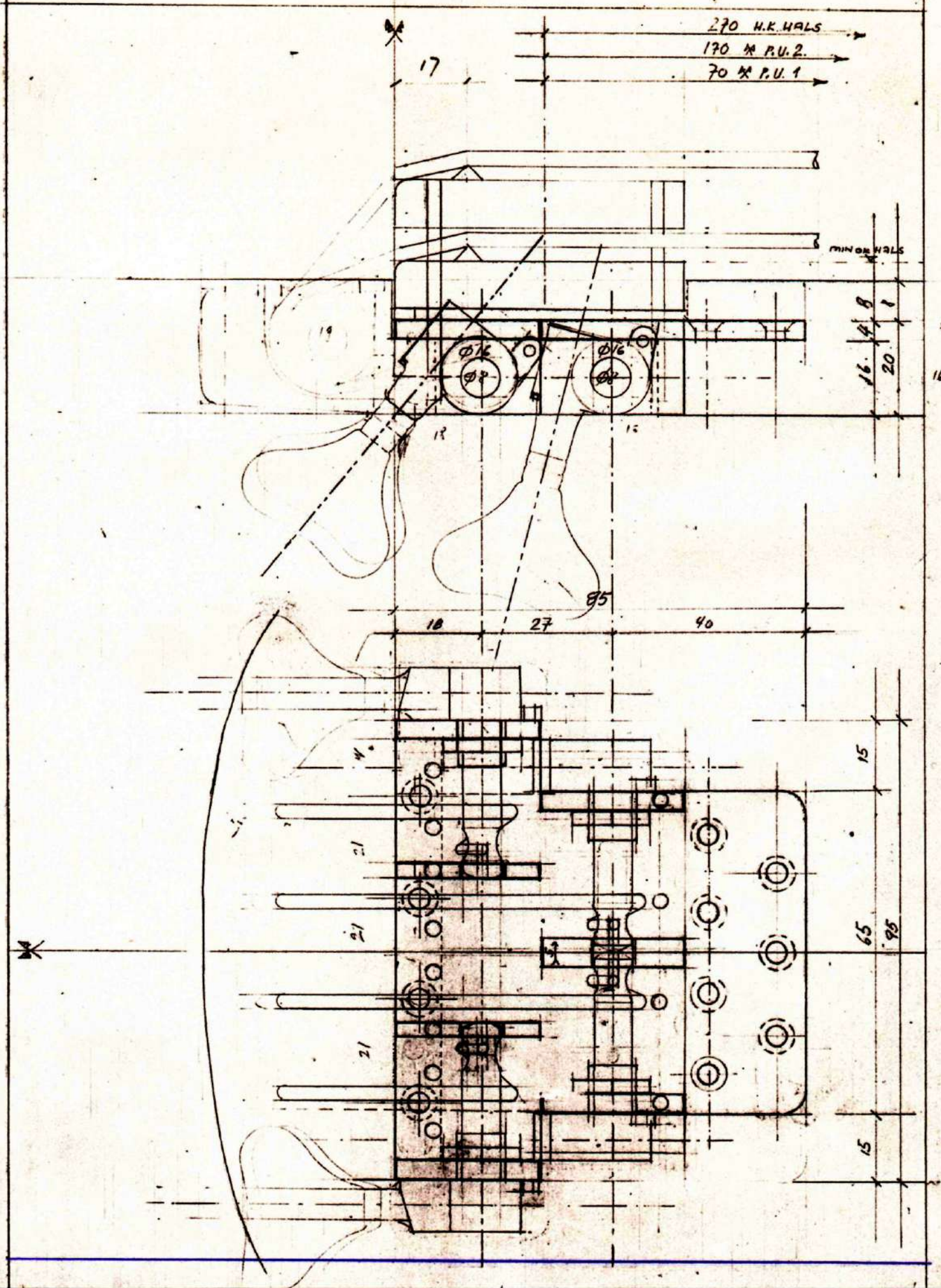

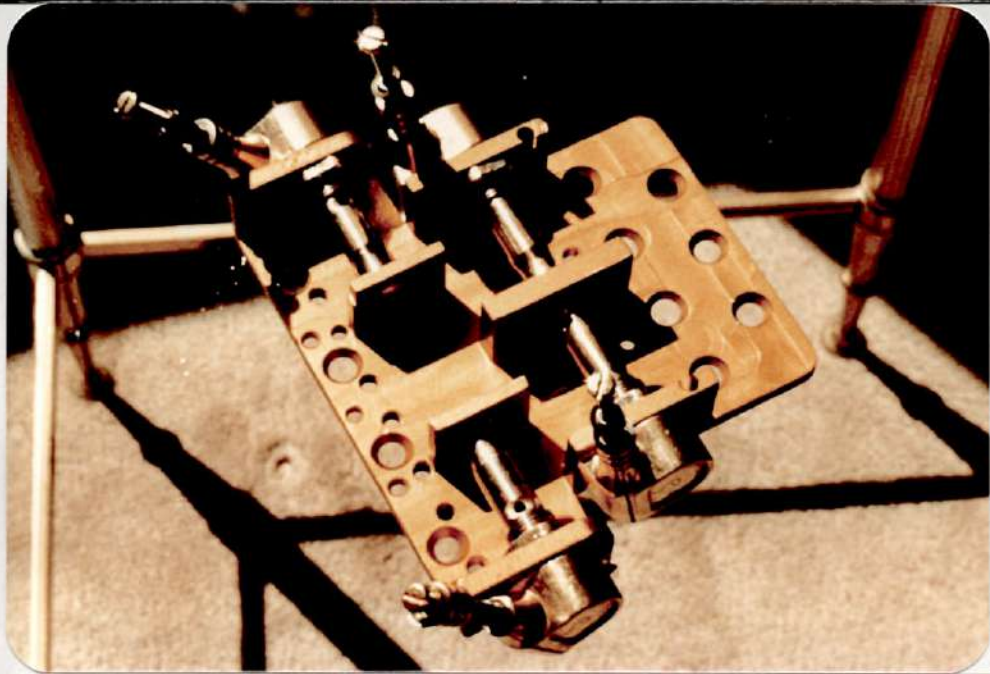
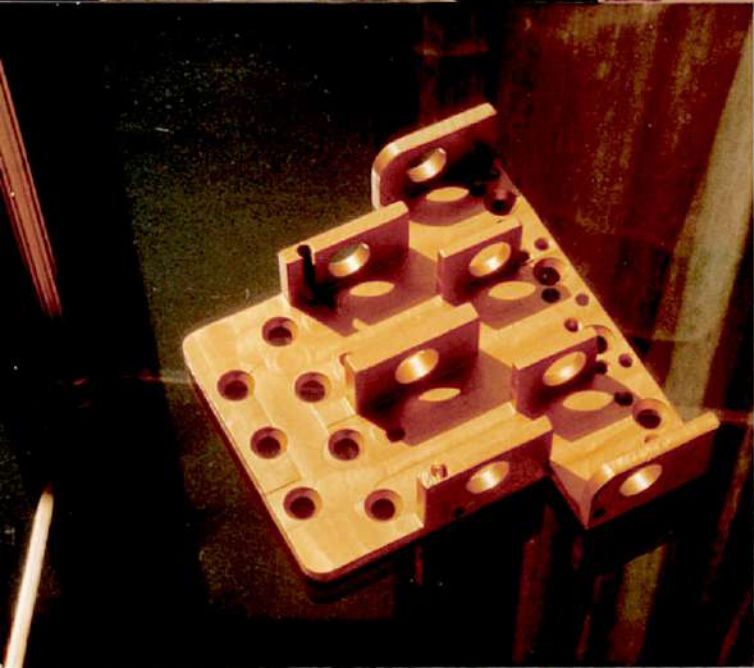
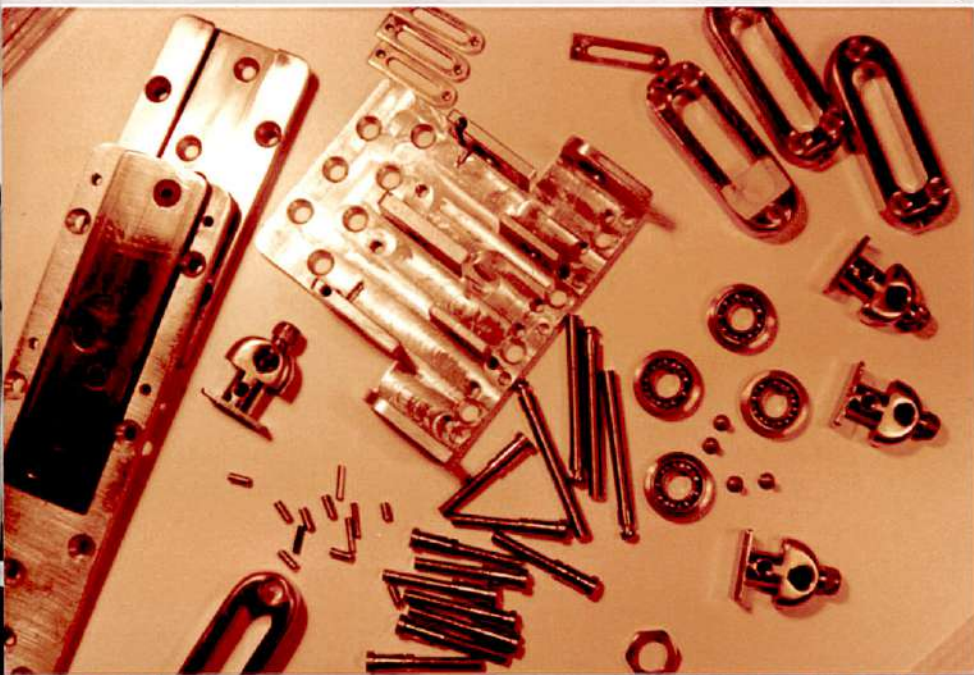
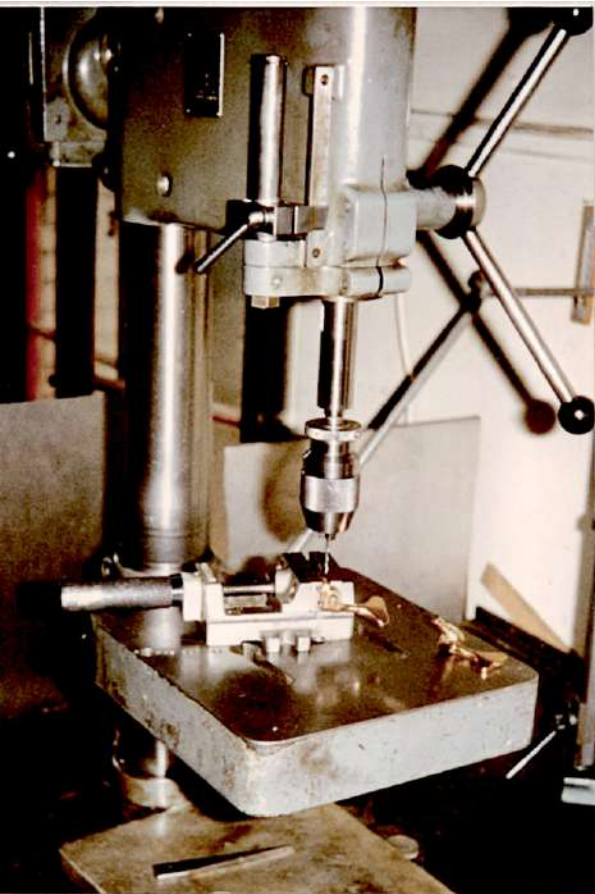

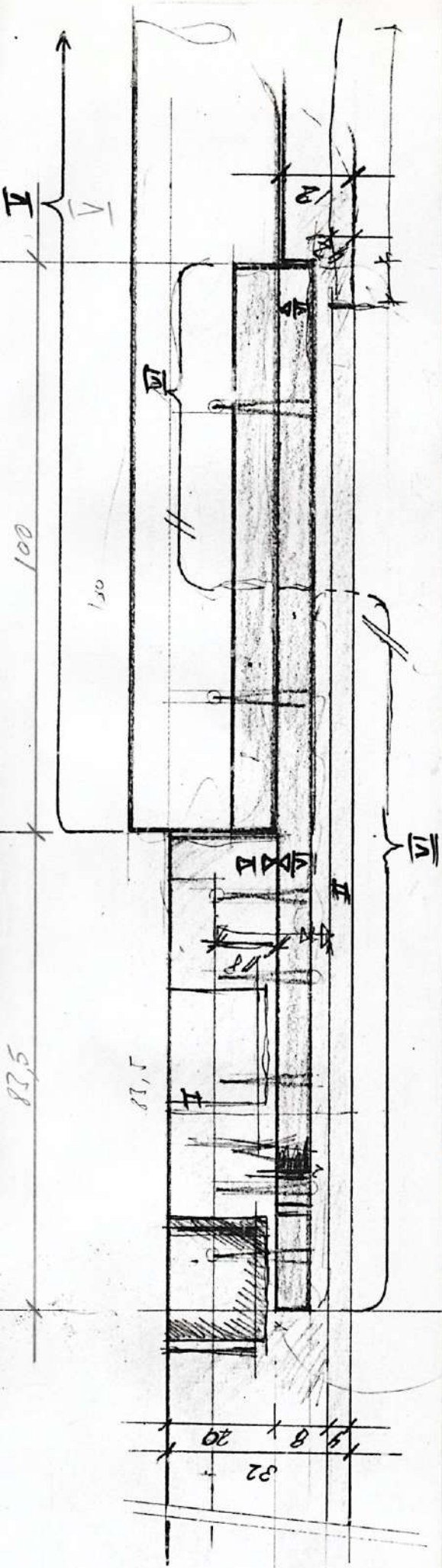

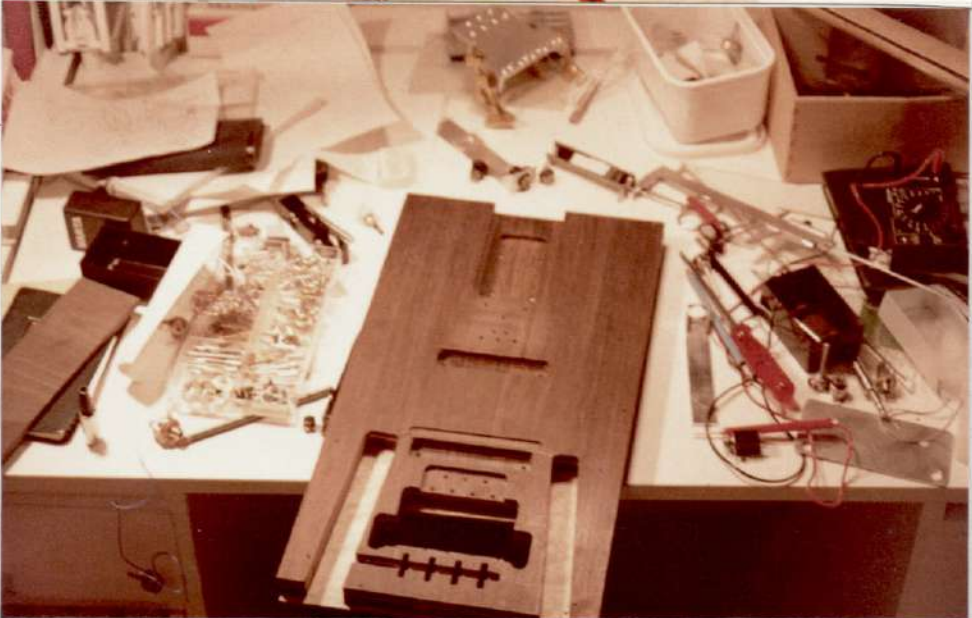
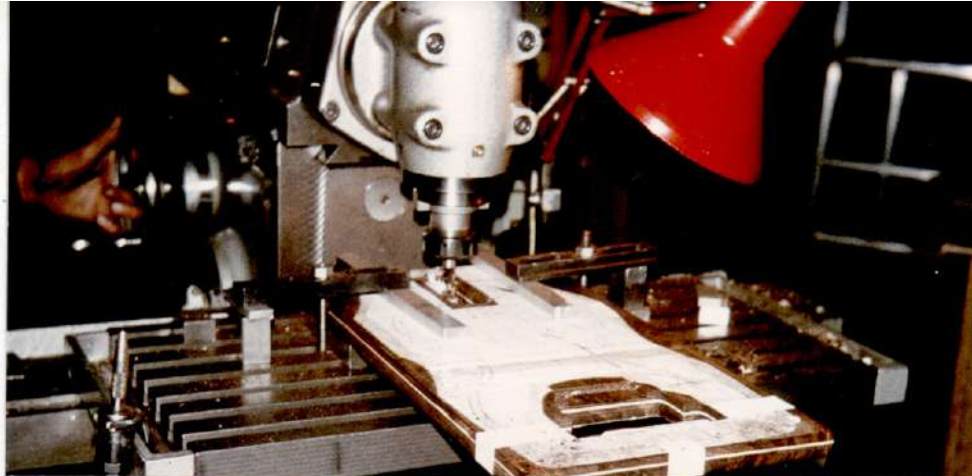
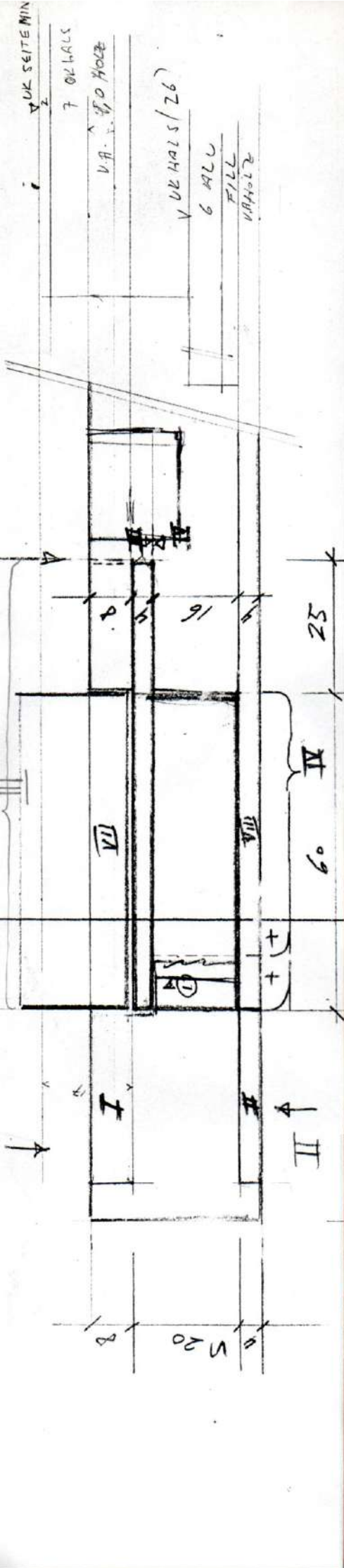



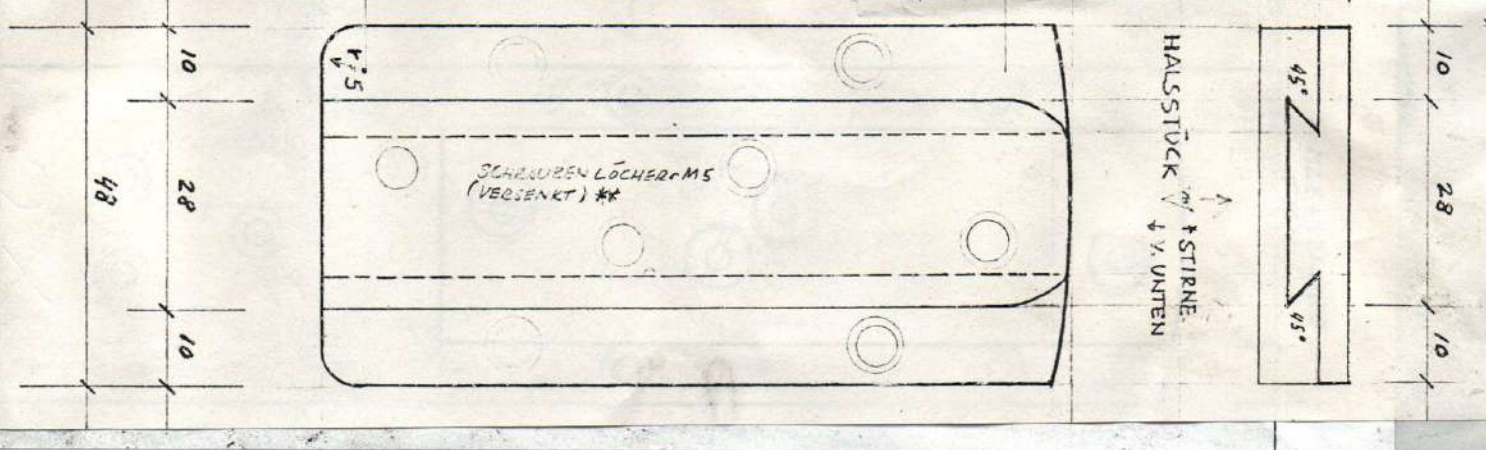
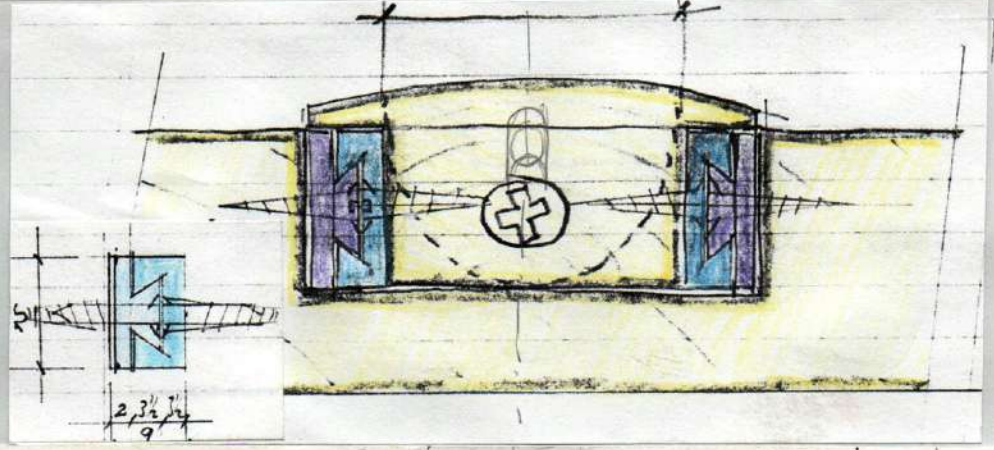
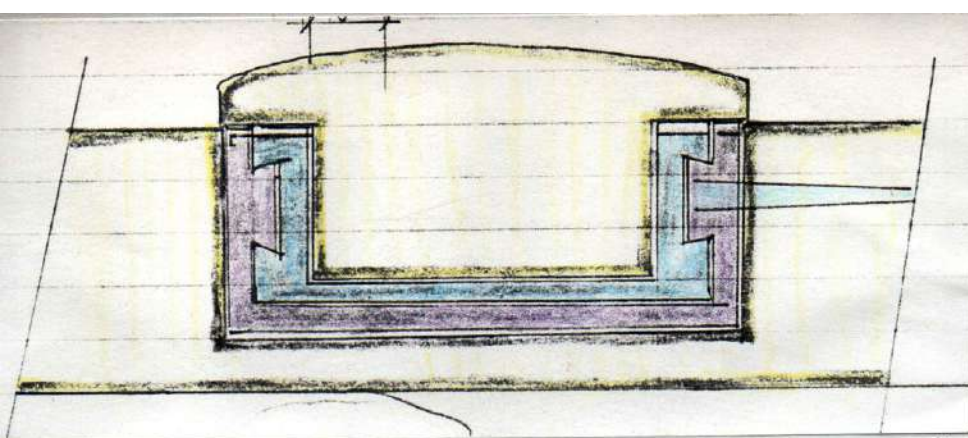

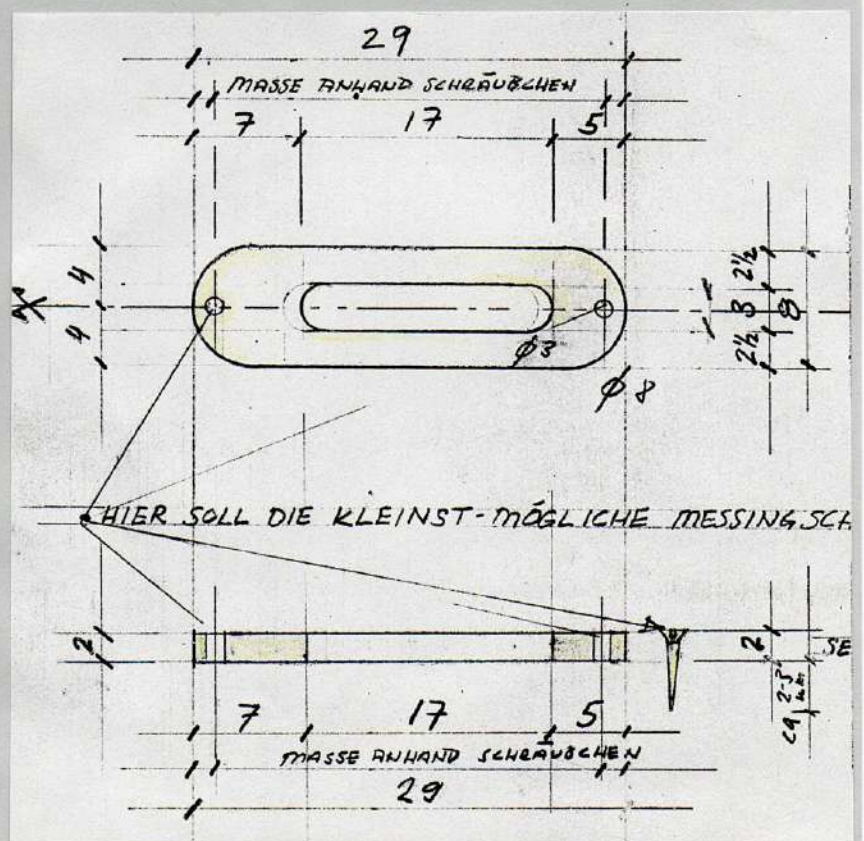
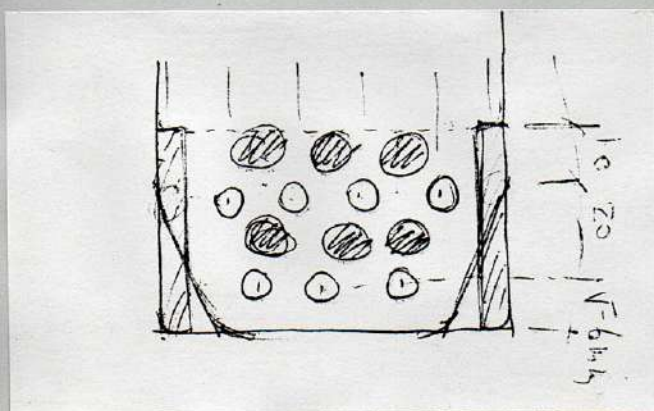
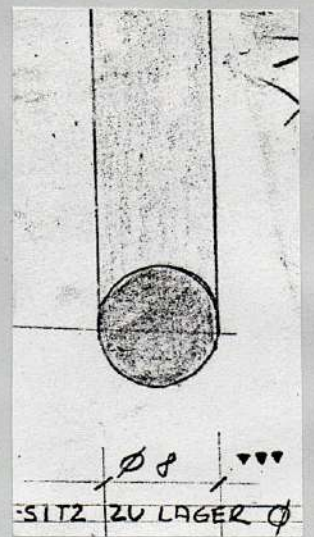
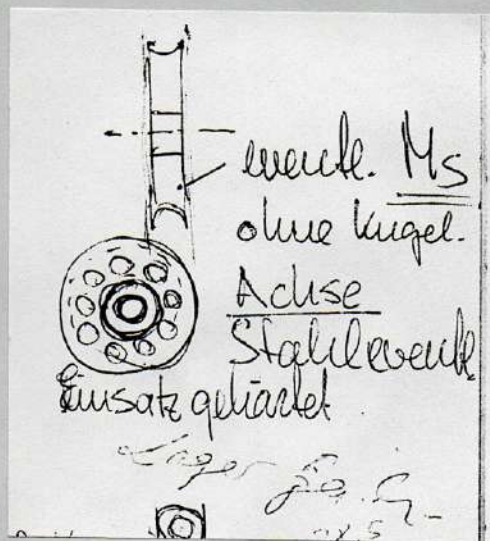
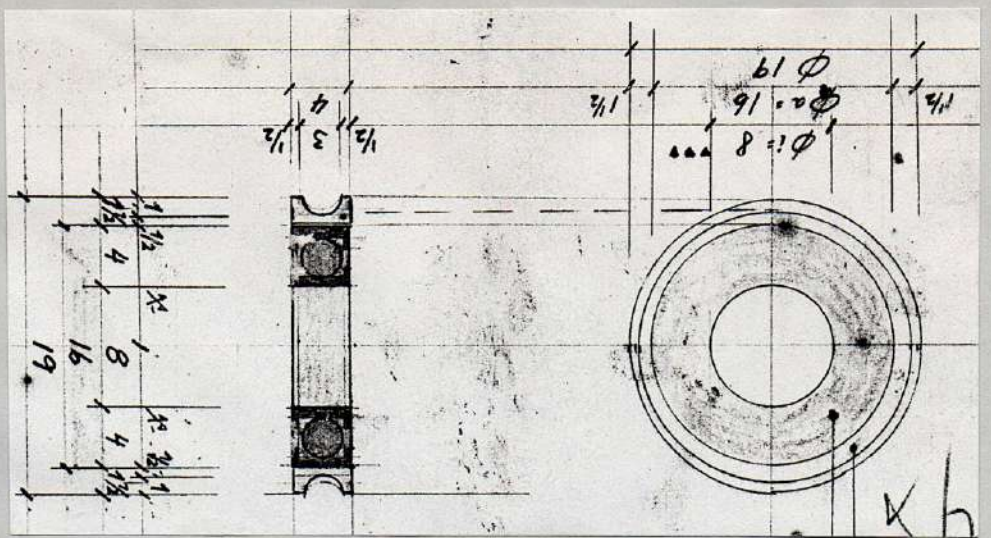
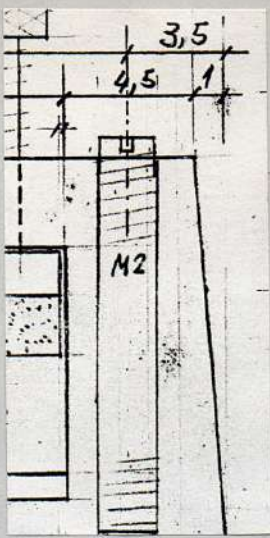

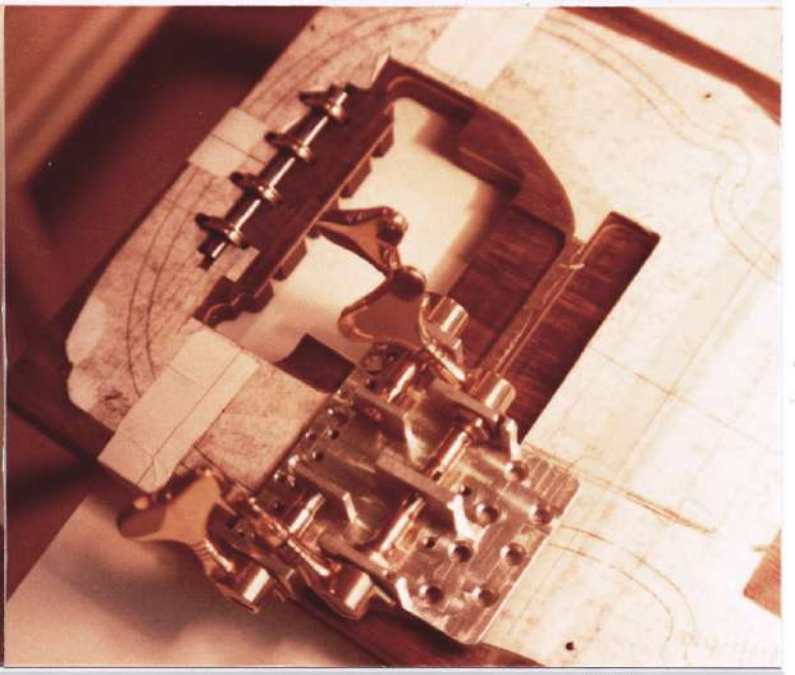
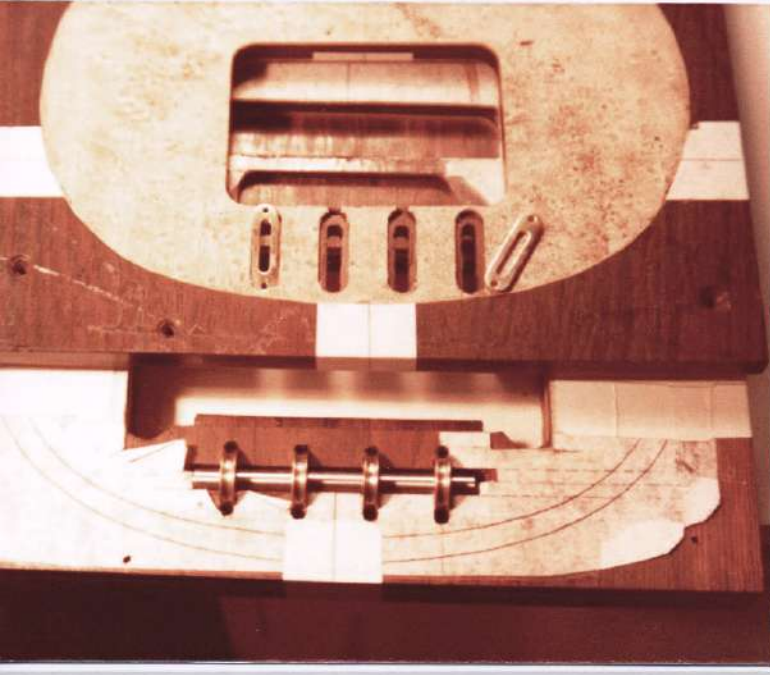
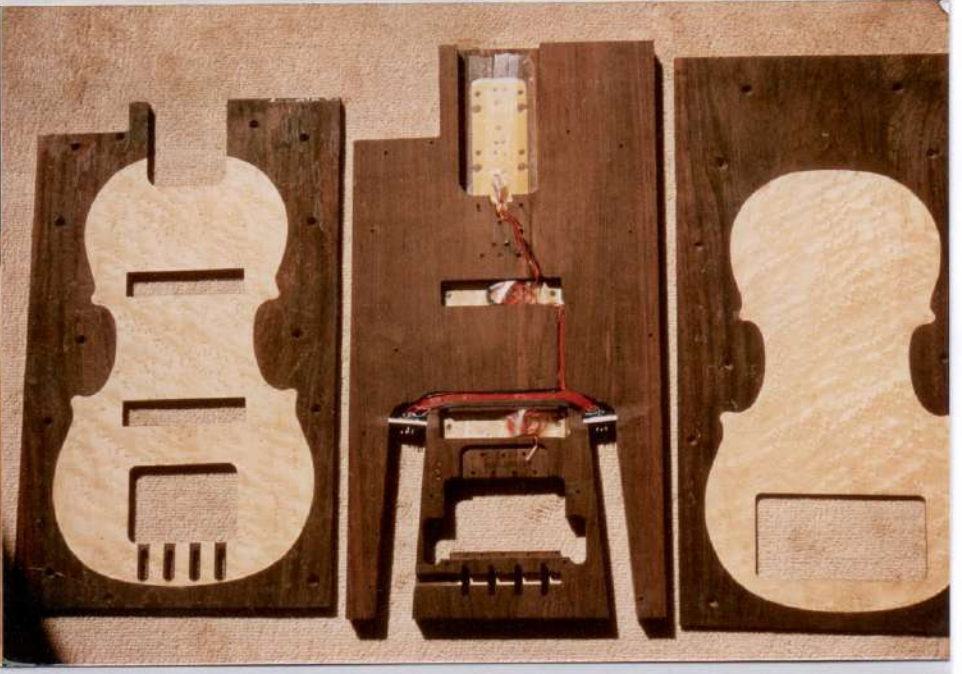
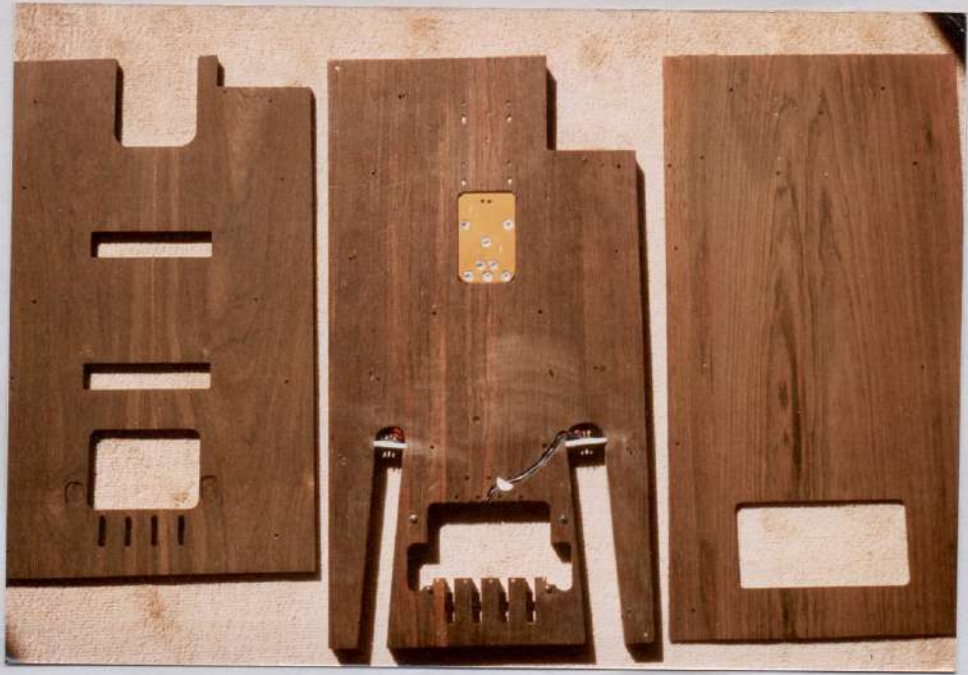

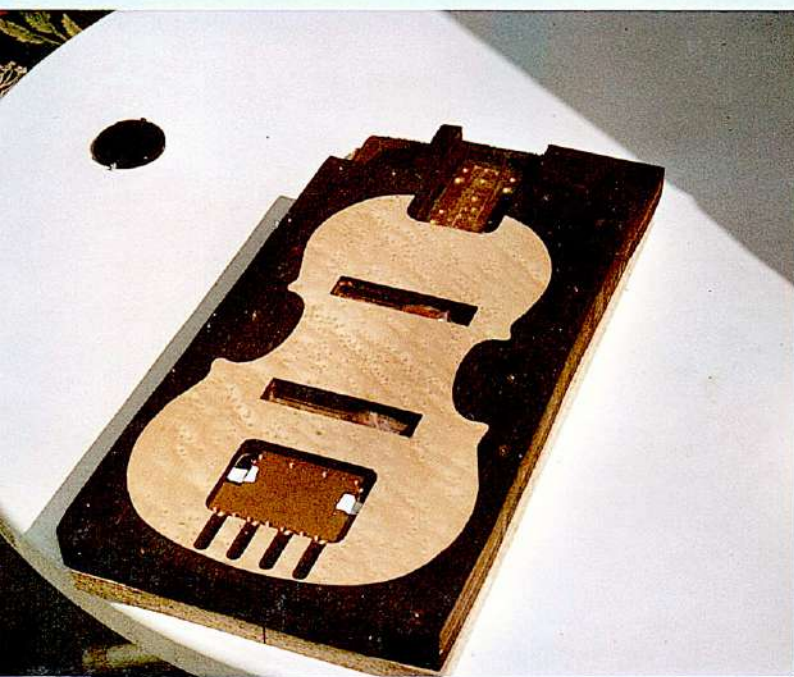

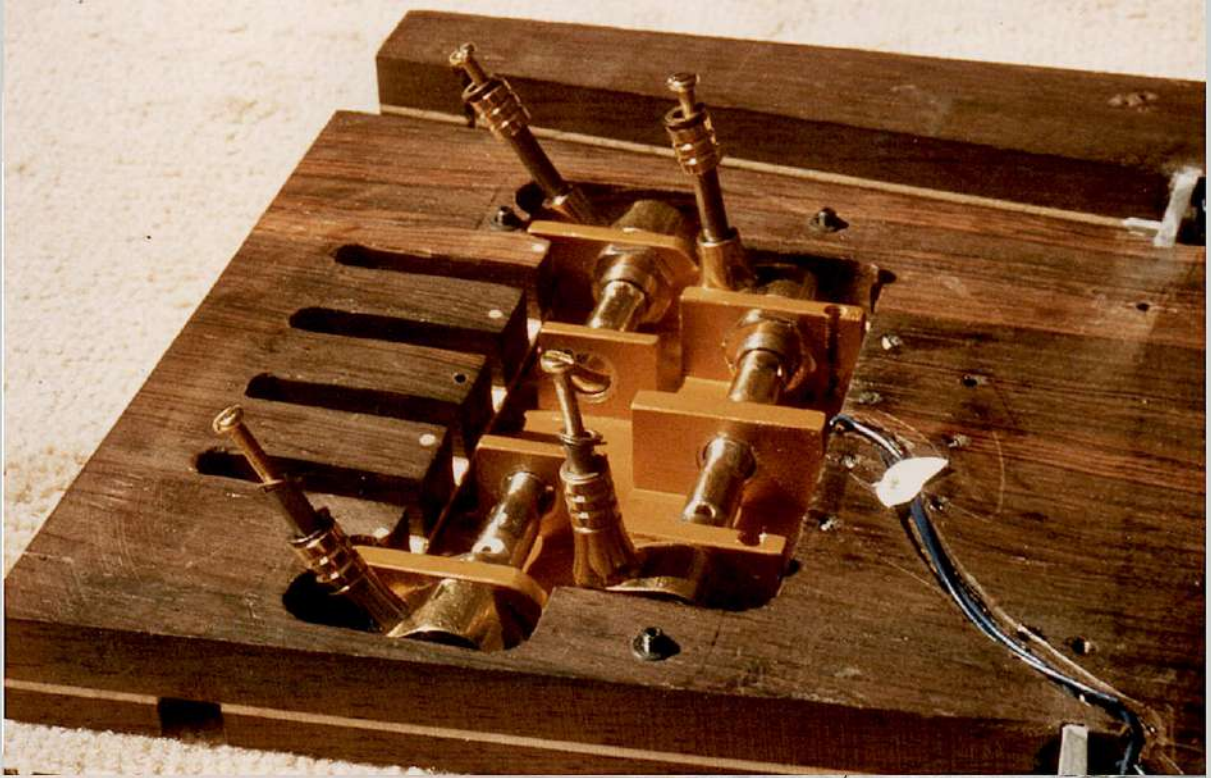

*Session*  
BASS VIOLIN

*Travel*  
BASS VIOLIN

x *Studio*  
BASS VIOLIN

*Eau de*  
BASS VIOLIN

*Flanders*  
BASS VIOLIN

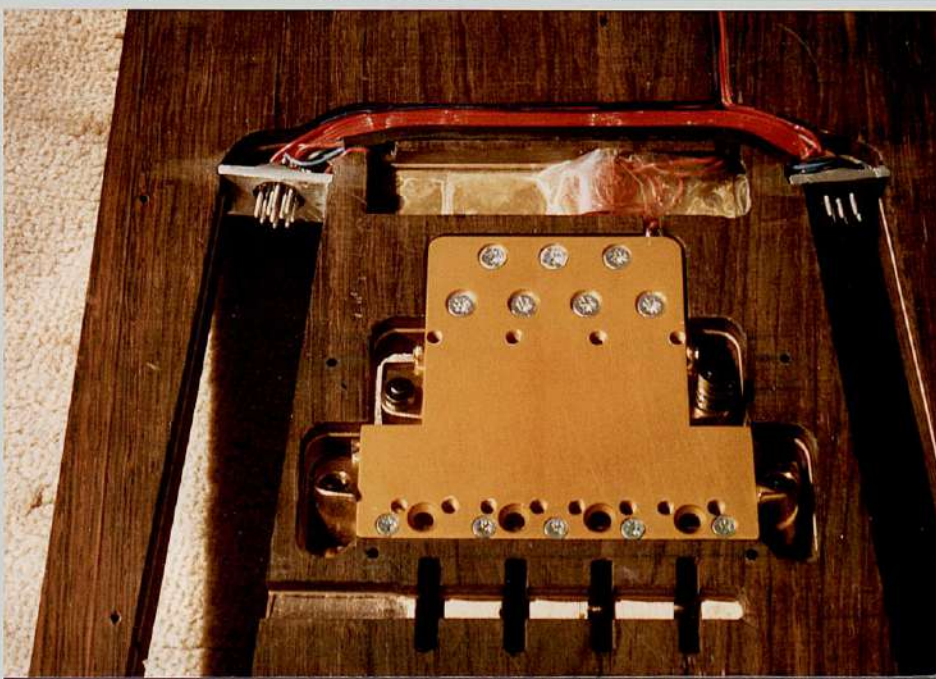





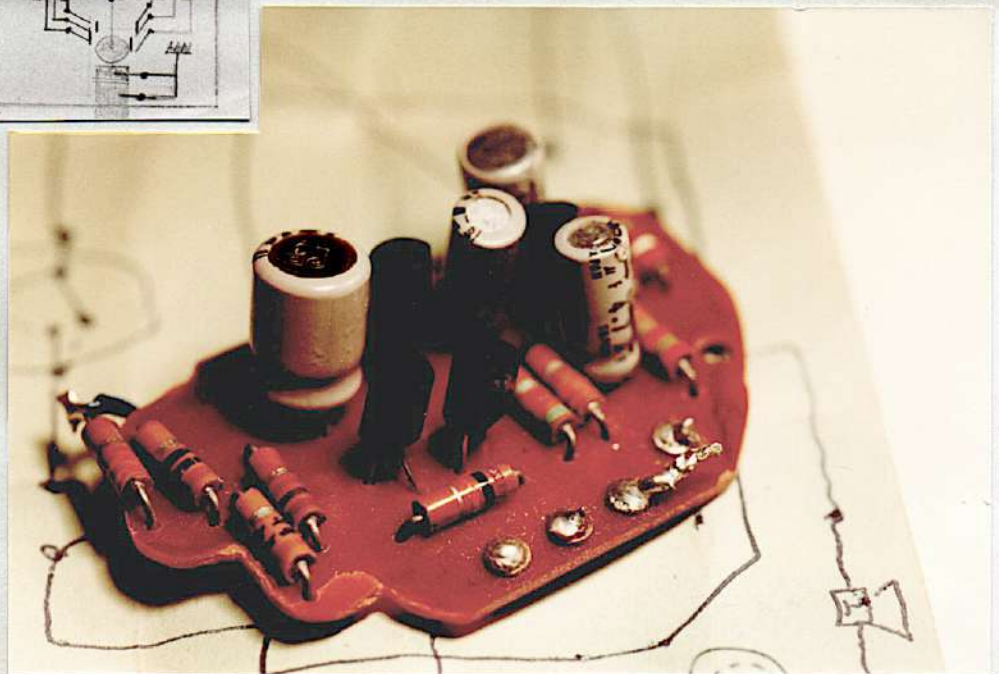
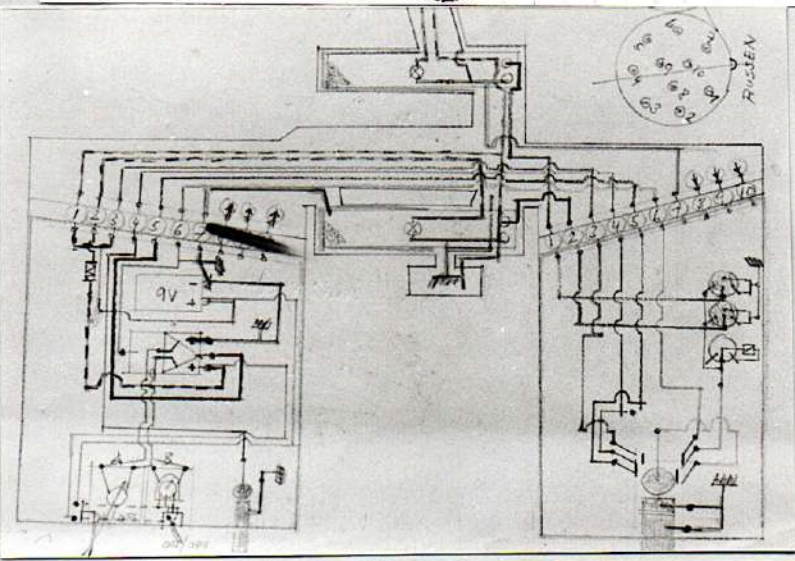
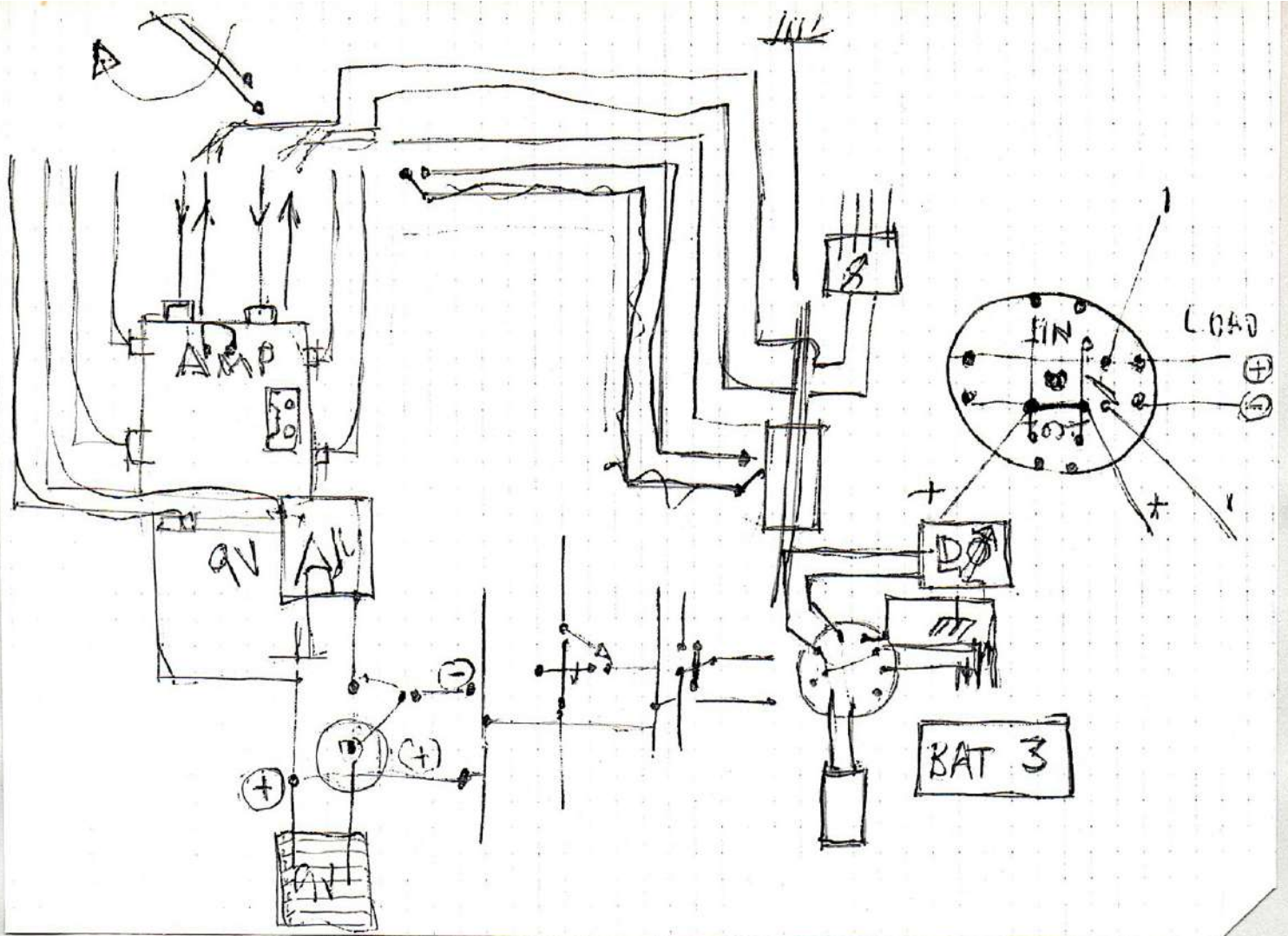





VERKABLUNGSSCHEMA BASSVIOLINE  
 EINGEBAUTES NETZ A  
 STECKMODUL NETZ B  
 L STECKMODUL IC  
 R STECKMODUL FENDER-KLANGREGELNETZW.  
 MUSIKSTUDIO PFANDLER  
 ZELTWEG 11a  
 CH-8032 ZÜRICH  
 03 391 2910 TOKYO

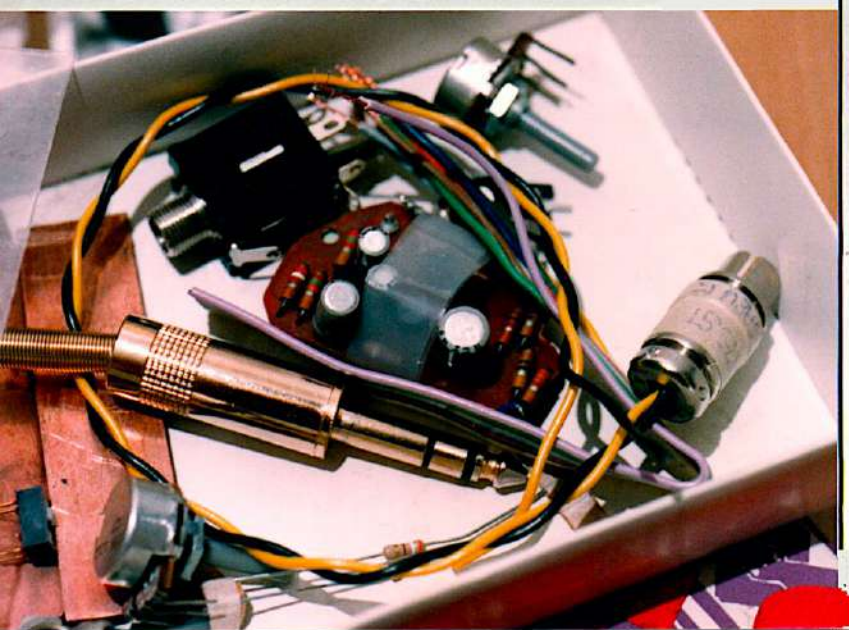
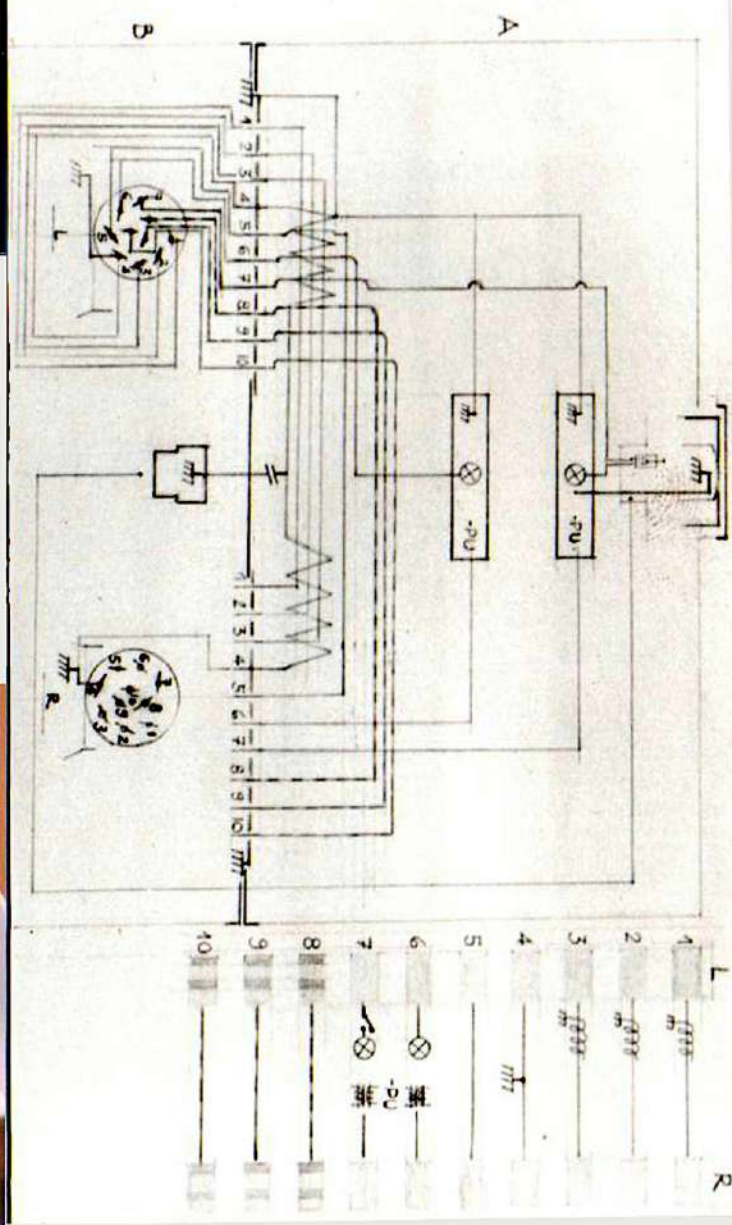

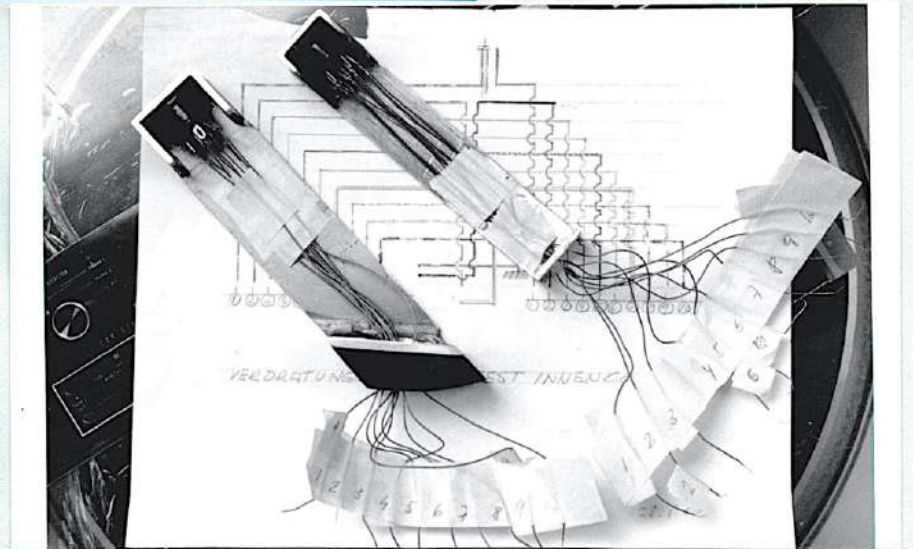
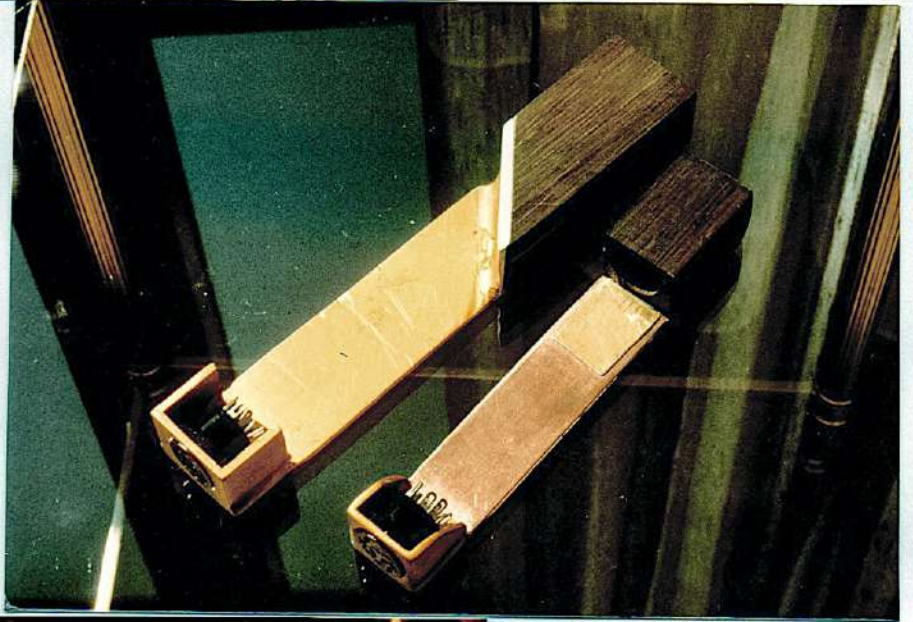
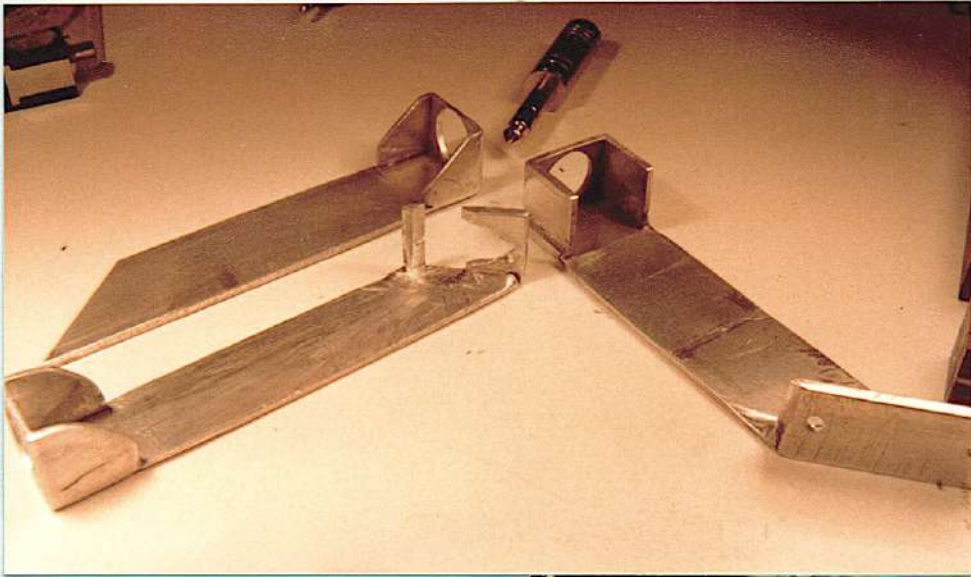

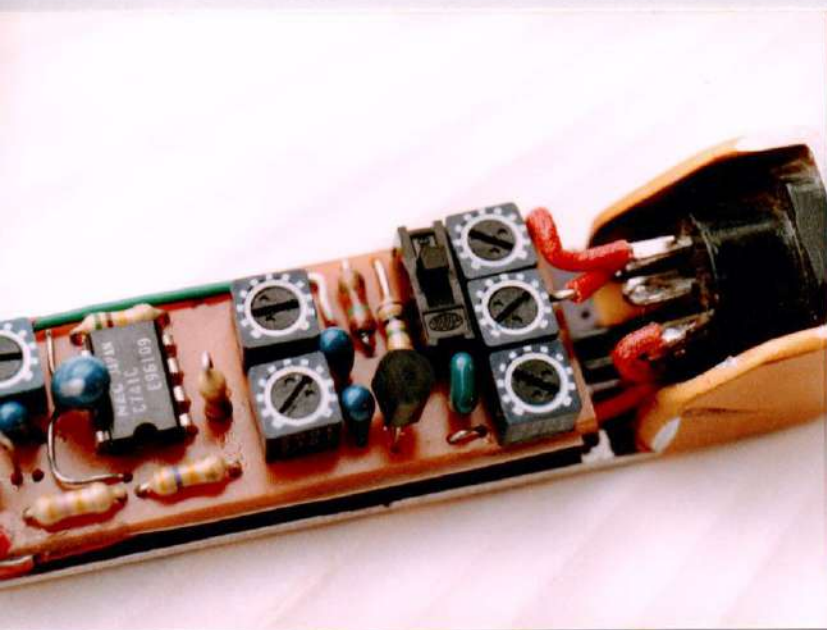
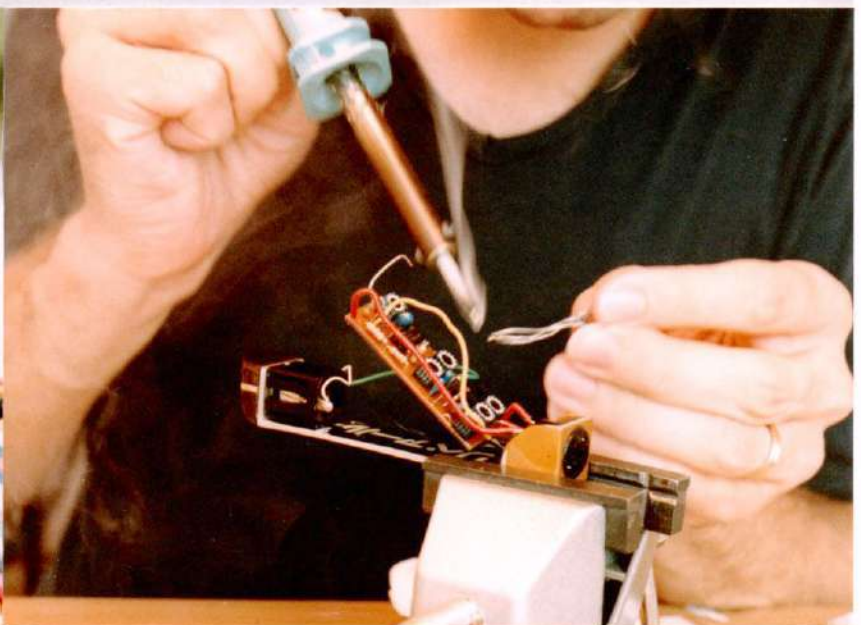
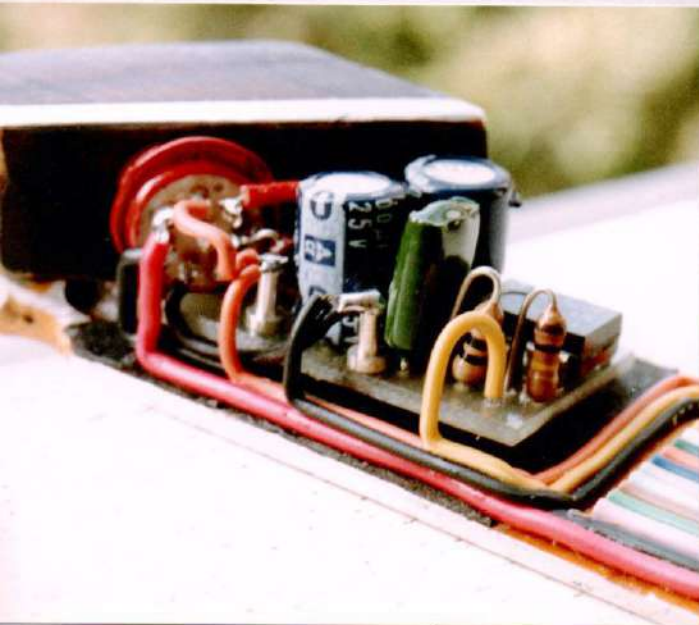

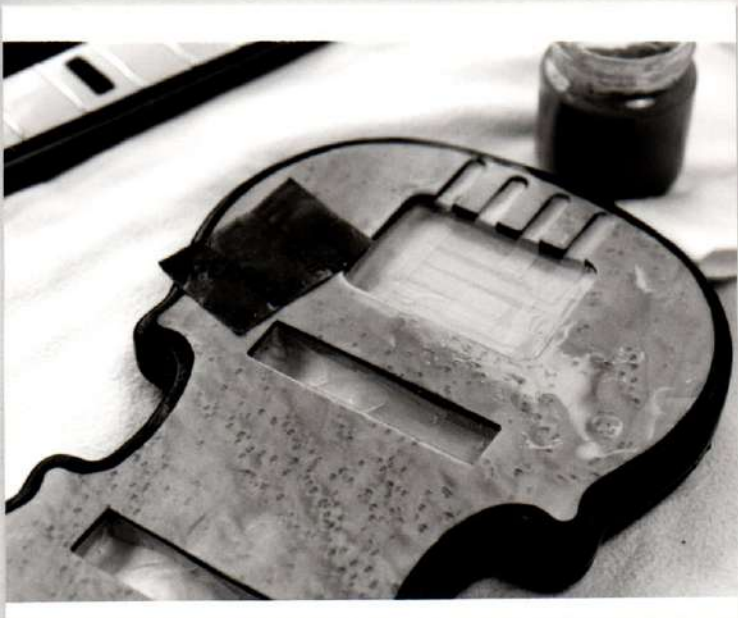





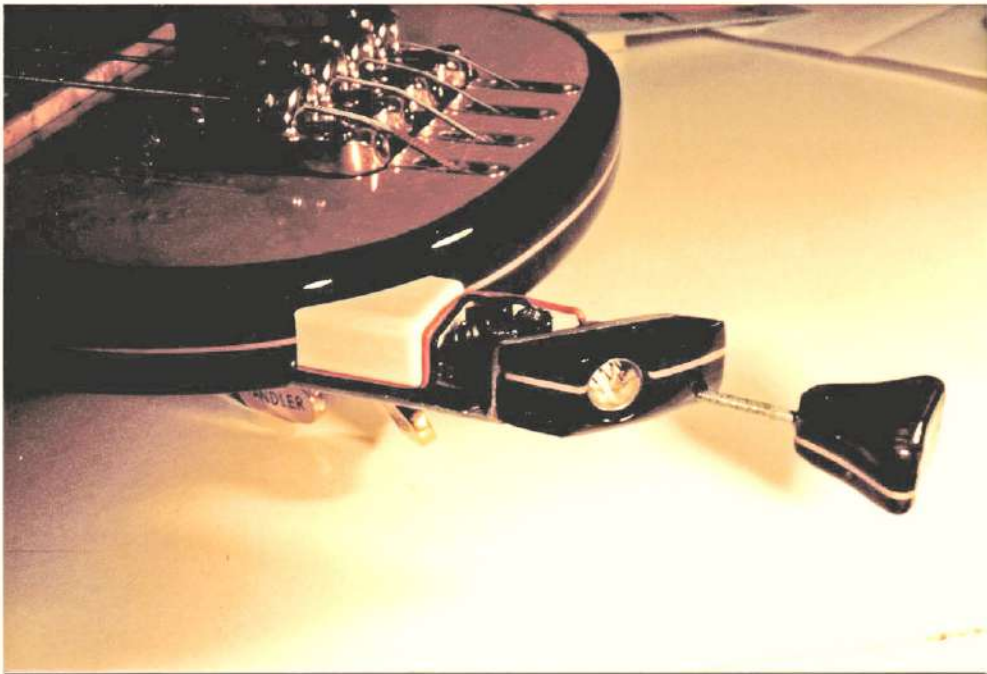

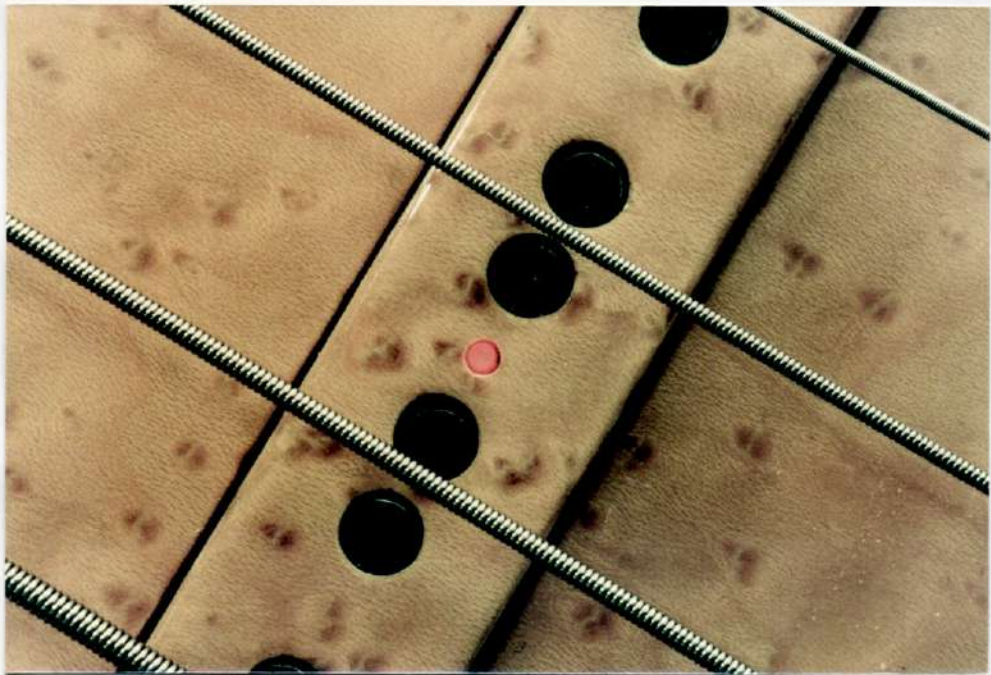
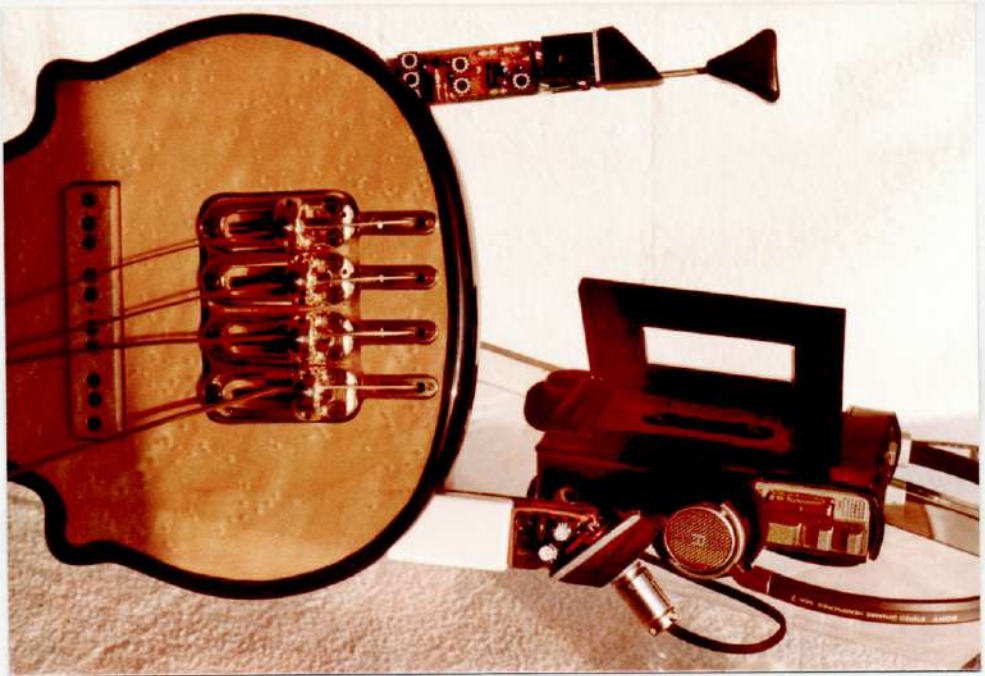
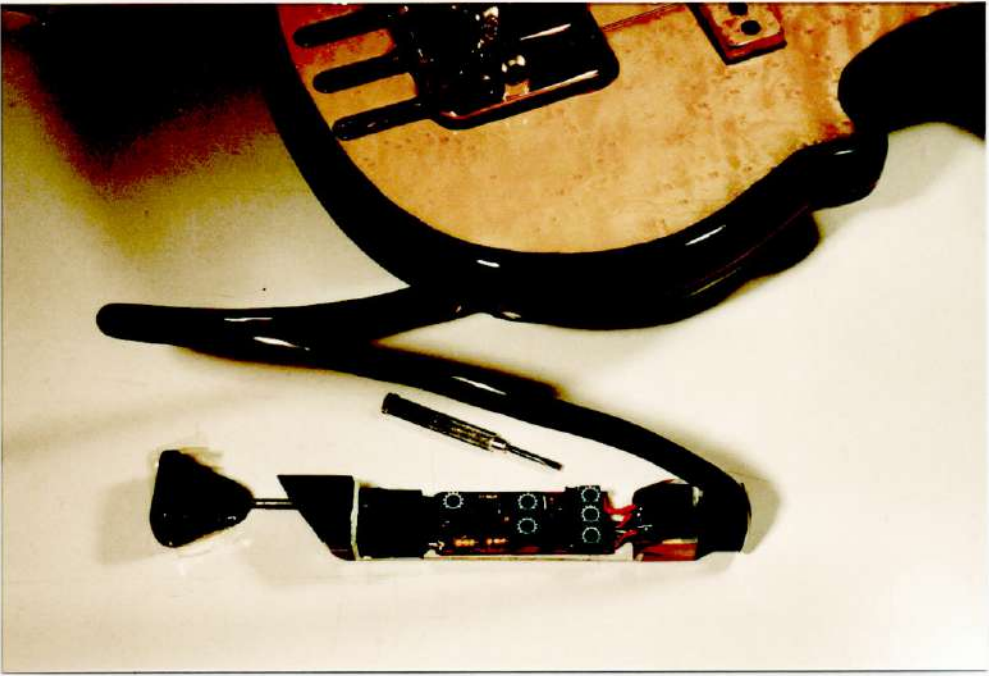



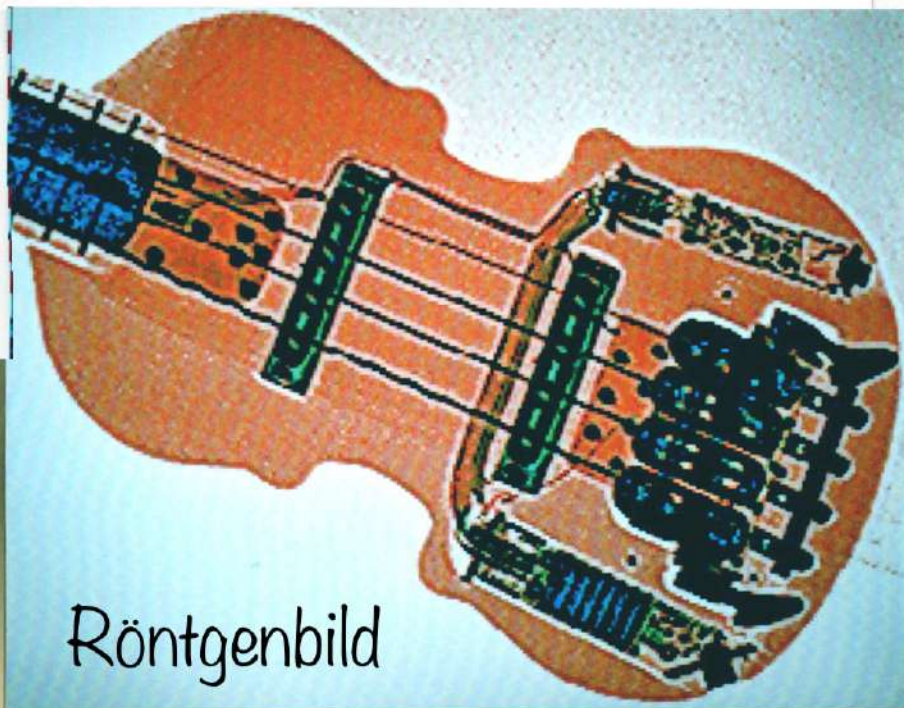

Röntgenbild

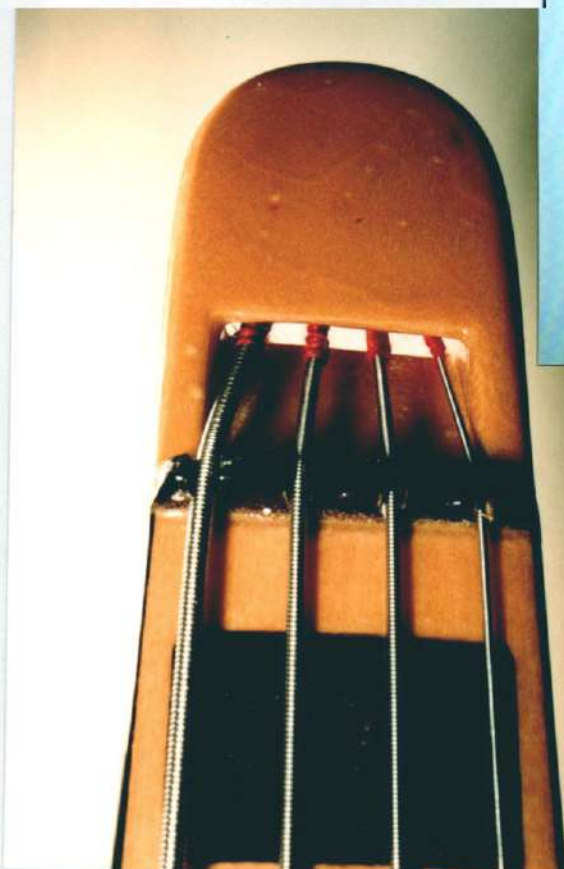

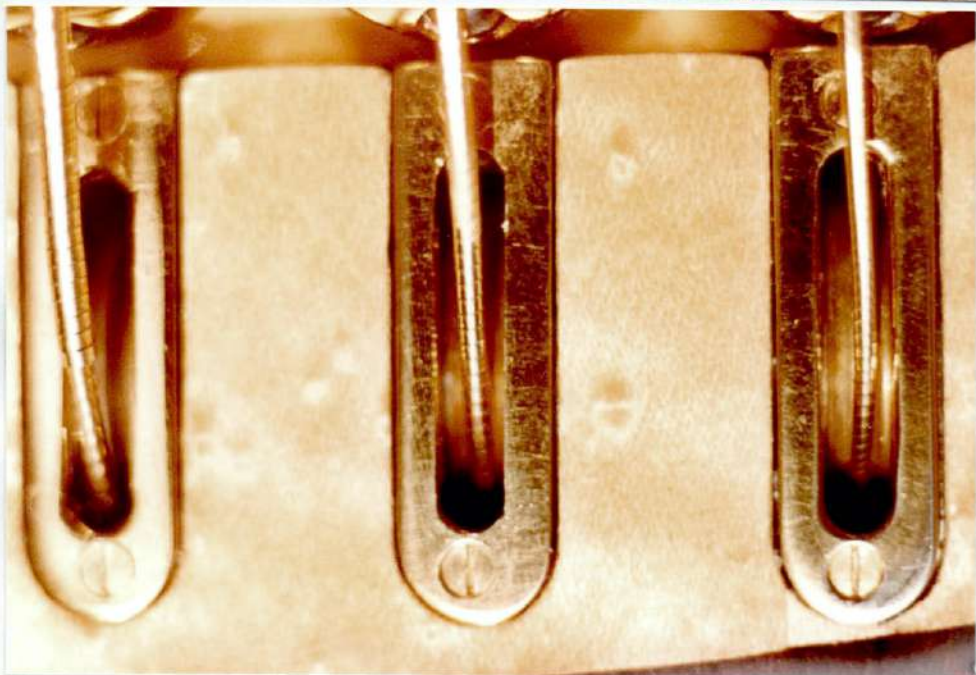
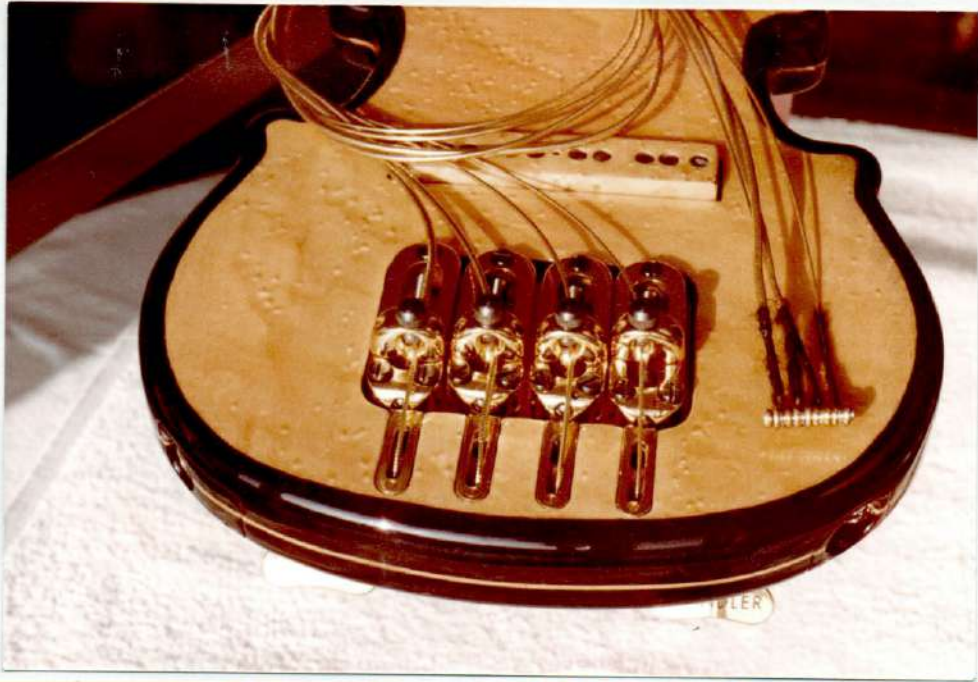

21.10.05 - 30.4.06



**Stromgitarren**

Legenden. Lärm. Leidenschaft.  
[www.stromgitarren.ch](http://www.stromgitarren.ch)

Museum für Kommunikation  
Bern

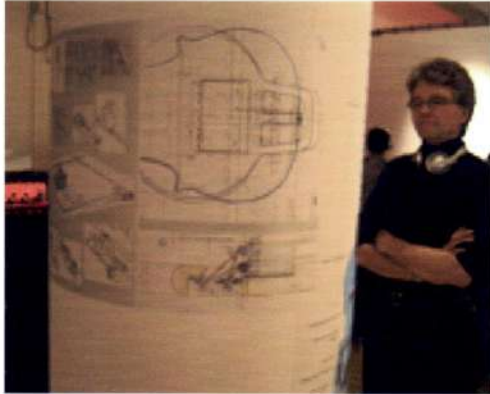

## Stromgitarren-Ausstellung



Museum für Kommunikation Bern

REPRINTED WITH PERMISSION OF

JULY 1982 \$1.75

# GUITAR WORLD

## The Police's STING

Power Bass, Pure Pop  
And All That Jazz

BASS  
ROUNDTABLE

Best of  
the  
Bottom

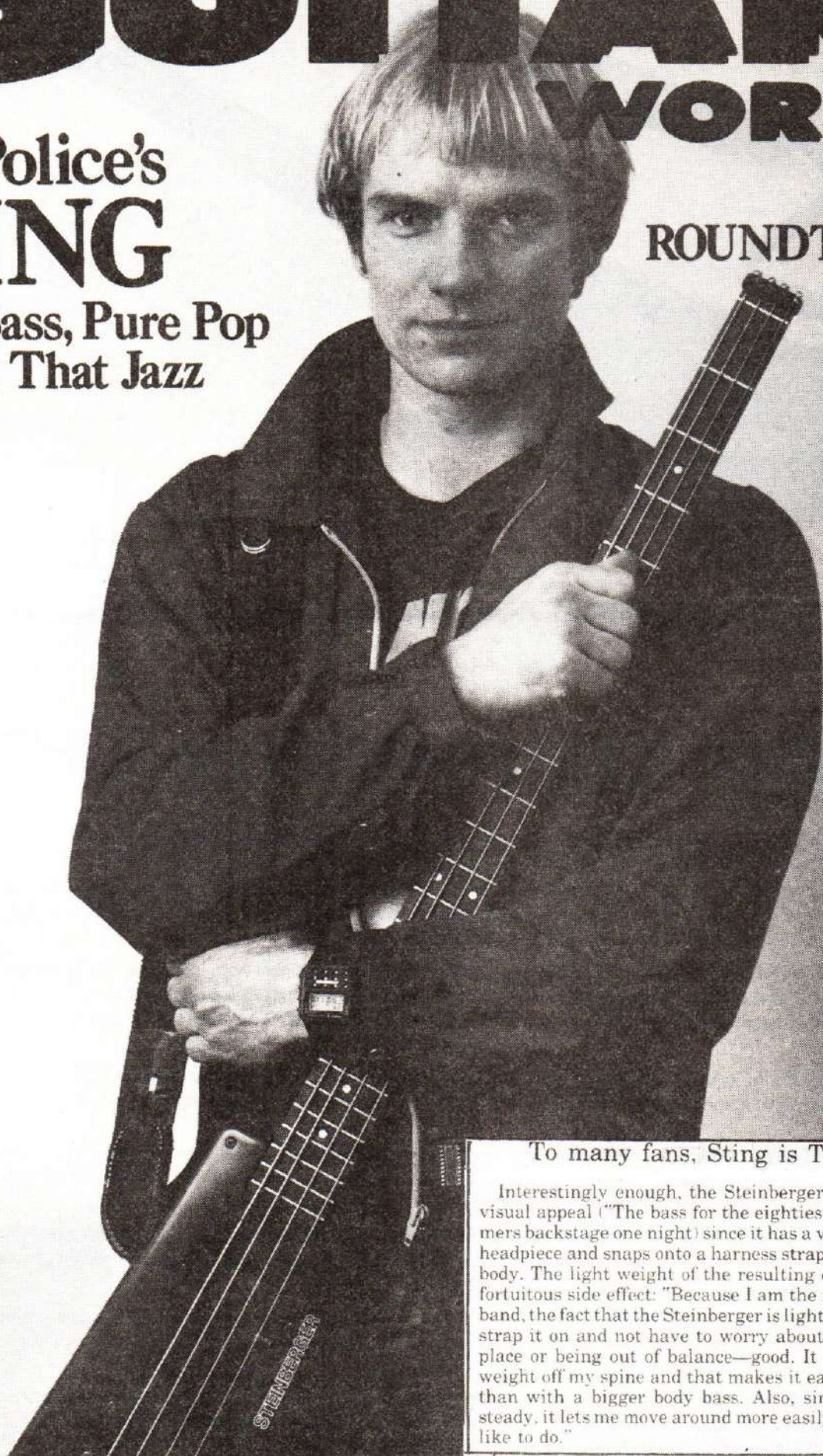

To many fans, Sting is The Police.

Interestingly enough, the Steinberger bass has its own visual appeal ("The bass for the eighties," said Andy Summers backstage one night) since it has a very small body, no headpiece and snaps onto a harness strapped to the player's body. The light weight of the resulting combination has a fortuitous side effect: "Because I am the main singer in the band, the fact that the Steinberger is light is important. I can strap it on and not have to worry about keeping it in one place or being out of balance—good. It takes some of the weight off my spine and that makes it easier for me to sing than with a bigger body bass. Also, since it is light and steady, it lets me move around more easily on stage, which I like to do."

Steinberger produziert den Bass

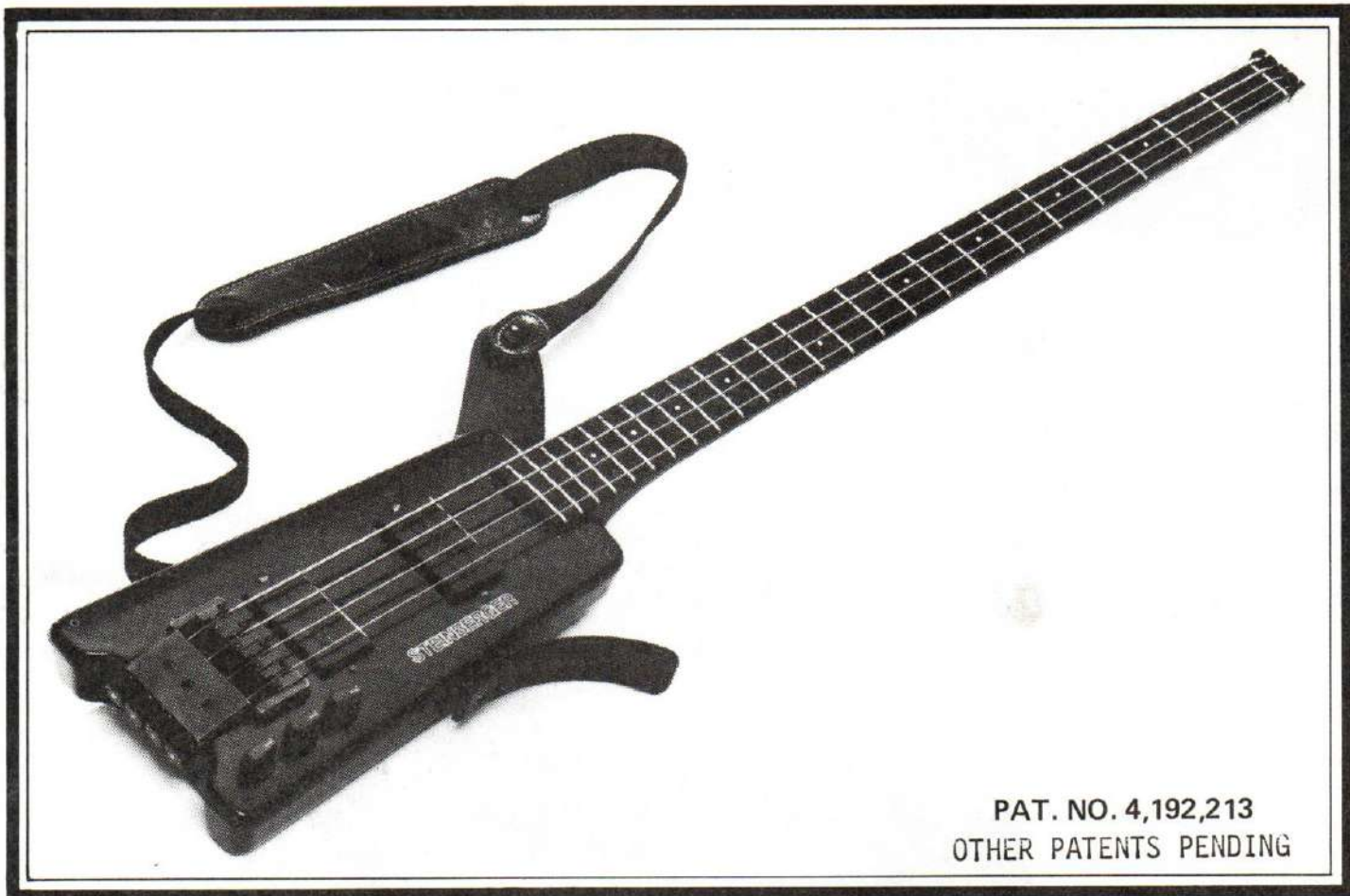

PAT. NO. 4,192,213  
OTHER PATENTS PENDING

1983

# THE STEINBERGER BASS

**RIGID ONE-PIECE CONSTRUCTION**—The neck and body are molded from one extremely rigid piece of graphite-fiber and glass-fiber reinforced epoxy resin, resulting in acoustical properties vastly superior to wood. This structure isolates the vibration of the string, resulting in extremely long decay (sustain) and increased harmonic content. In addition, it eliminates dead spots common to all wooden necks. The neck will not warp or bend, even under the highest string tension. The hard polyester gel coat finish resists scratching and is impervious to moisture.

**BRILLIANT SOUND** — Rigid structure and massive bridge configuration combine to produce the ultimate in brilliance, clarity and sustain. Increased harmonic content results in tone which is bright and alive, consistently responsive on all areas of the fingerboard, with unusual versatility and dynamic range. The bass opens up a new range of sound to the player.

**COMPACT SIZE** — Advanced design eliminates the conventional peghead by locating the tuners on the body. The result is an extremely compact instrument measuring less than 38 inches overall, with full 34-inch scale length and 24 frets.

**EXCELLENT BALANCE** — Without peghead weight, overall balance is greatly improved. Strap support plate pivots at exact center of gravity, allowing instrument to be played at any angle in perfect balance, with full access to all 24 frets. For seated playing, a snap-on legrest is provided.

**PRECISION HARDWARE** — All hardware is machined from solid brass and stainless steel. The bridge is fully adjustable with unique locking mechanism. Accurate tuning is accomplished by means of a simple threaded rod and knob which cannot accidentally detune (equivalent 40:1 ratio).

**DOUBLE BALL-END STRING SYSTEM** — The Steinberger Bass introduces an instant-change double ball-end string. Strings can be removed and reattached repeatedly without damage to the windings. Conventional strings can also be used.

**ACTIVE ELECTRONICS** — Steinberger Bass Models L-1 and L-2 are equipped with state-of-the-art low impedance pickups for extended frequency response and improved signal-to-noise ratio (very quiet). Sound quality is unaffected by cable length. Accepts standard ¼" phone jack; requires no modification of amplifier.

Yamaha kopiert auf Anfrage

# Riverhead UNICORN SERIES

*The very latest technology and the craftsmanship  
cultivated over many years*

*by Headway Co., Ltd. have brought a mythical legend to life in  
the Riverhead "Unicorn Series" of electric guitar and basses,  
combining the very latest Technology and design  
with old world craftsmanship.*



# Gitarre & Bass

DAS MUSIKER-FACHMAGAZIN

→ Steve Morse

Nightwish

Steve Vai

Bob Daisley

Marcus Miller

Tal Farlow

Judas Priest

Albert Collins

Mando Diao

Robert Randolph

Charlotte Hatherley

**WEWILLROCKYOU!**

## test

- Epiphone Ellist Sheraton E-Gitarre
- Ayers AYMSM Akustik-Gitarre
- ESP Viper E-Bass
- Ibanez Prestige RGA121-NTF E-Gitarre
- Fender American Deluxe QMT V Jazz Bass
- Atomic Reactor-112 Power Tube Combo
- Ibanez Prestige RGA121-NTF E-Gitarre
- Onerr Effektpedale
- Boss RC-20XL Loop Station

# NAMM SHOW NEWS

Inside: Die Erfindung des ersten Headless Bass

